



Monterra Community Development District

**July 1, 2026
Agenda Package**

[Meeting Link](#)

Meeting ID: 835 2689 2974 Passcode: 665564

11555 HERON BAY BOULEVARD, SUITE 201
CORAL SPRINGS, FLORIDA 33076

CLEAR PARTNERSHIPS



COLLABORATION



LEADERSHIP



EXCELLENCE



ACCOUNTABILITY



RESPECT

Monterra Community Development District

Board of Supervisors

Jason Weinrub, Chairman
Juan Carlos Sanchez, Vice Chairperson
Avi Ciechanowiecki, Assistant Secretary
Susan Kooiman, Assistant Secretary
Greg Popowitz, Assistant Secretary

District Staff

Jennifer Goldyn, Director of District Services
Lynne Ladner, District Manager
Ginger Wald, District Counsel
Peter Pellerito, District Engineer
Richard Almeida Clubhouse Manager
John Khatiblou, Accountant
Melinda Gallo, Administrative Assistant

Regular Meeting Agenda

Wednesday, July 1, 2026, at 6:00 p.m.

The Regular Meeting of the **Monterra Community Development District** will be held on Wednesday July 1, 2026, at 6:00 p.m. at Club Monterra, 8451 Monterra Boulevard, Cooper City, Florida 33024. Please let us know at least 24 hours in advance if you are planning to call into the meeting. Following is the Agenda for the Meeting:

[Meeting Link](#)

Meeting ID: 835 2689 2974

Passcode: 665564

THE REGULAR MEETING OF BOARD OF SUPERVISORS

1. CALL TO ORDER/ROLL CALL
2. PLEDGE OF ALLEGIANCE
3. APPROVAL OF AGENDA
4. PUBLIC COMMENTS

(Each individual has the opportunity to comment and is limited to three (3) minutes for such comment)

5. STAFF REPORTS

A. Financial Overview

- i. Review of Financial Summary for May 2026..... Page 4
- ii. Review of Cash Flow Predictions..... Page 5
- iii. Review of Financials May 2026 Page 6

B. District Counsel

- i. 2026 Legislative Update Memorandum..... Page 22

C. District Engineer

- i. Discussion of Spectator Seating Options for Basketball/Pickleball Courts..... Page 28

D. Clubhouse Manager

- i. Consideration of Cintas Floor Mat Rental Proposal Page 57
- ii. Consideration of UniFirst Floor Mat Rental Proposal Page 62

E. District Manager

- i. Review of District Manager Report..... Page 64

6. BUSINESS ITEMS

- A. Consideration of Revisions to the Clubhouse Rules and Regulations and
Setting of a Public Hearing Date..... Page 71
- B. Consideration of the Purchase of Two (2) Bleacher Seating Structures for the
Renovated Basketball/Pickleball Courts Page 83
- C. Consideration of Storm Drainage System Cleaning Services Proposal Page 146
- D. Consideration of Mailed Notice for Fiscal Year 2027 Page 150

7. BUSINESS ADMINISTRATION

- A. Consideration of the Minutes of the Meeting held on June 3, 2026
(Under Separate Cover)

8. NEW BUSINESS AND BOARD OF SUPERVISORS REQUESTS

9. ADJOURNMENT

MONTERRA COMMUNITY DEVELOPMENT DISTRICT

Financial Snapshot May 31, 2026

- **Current Cash Balances:**
 - Bank United Operating: \$532,076
 - Bank United MMA: \$3,136,726
 - SBA – Florida Prime : \$859,273
- **Assessment collections:**
 - We received a tax distribution of \$13,949 on 05/15/26.
 - We are 103% collected (due to interest on late payments) on the tax roll with a total outstanding of \$0 and the GF total revenue is 103% of adopted budget.
- **Audit – FY 2025:**
 - The audit has been completed with no findings.
- **Expenses:**
 - Current expenses make up 74% of the annual budget through the end of May 2026
 - Total expenses for the first 8 months are approximately \$2,550,283. This puts your average monthly burn rate of approximately \$318,785 per month.

Monterra CDD
Cash Flow Projection
5/31/2026

	<u>Balances</u>	<u>Interest Rate</u>
Operating Account - Bank United	532,076	0.00%
MM Account - Bank United	3,136,726	3.40%
SBA - Florida Prime #2511	419,596	3.81%
SBA - Florida Prime #2400	439,677	3.81%
Public Special MRC - Truist	10,312	1.55%
Less: Current Outstanding AP	(157,233)	
Estimated Cash Available Today	4,381,154	
Outstanding FY26 Tax Roll	-	
Estimated Total Cash Available with Tax Roll	4,381,153	
<u>Projections:</u>		
Monthly Average Spend - (8 Months Oct-May)	318,785	
Total Monthly Average Spend	318,785	
Average Spend to YE - (4 months Jun - Sept)	1,275,142	
Expected Cash Flow at YE (9/30/26)	3,106,012	
Average Spend 1st QTR FY27 - (2 mos avg spend)	637,571	
Expected Need through 1st QTR FY27	2,468,441	
<i>*tax roll revenue for the new FY is received in December</i>		

*Monterra
Community
Development
District*

Financial Report

May 31, 2026

CLEAR PARTNERSHIPS



Table of Contents

<u>FINANCIAL STATEMENTS</u>	<u>Page</u>
Balance Sheet - All Funds	1 - 2
Statement of Revenues, Expenditures and Changes in Fund Balance	
<u>General Fund</u>	3 - 5
 <u>SUPPORTING SCHEDULES</u>	
Cash and Investment Report	6
Trend Report - General Fund	7
Payment Register	8 - 12

**Monterra
Community Development District**

Financial Statements

(Unaudited)

May 31, 2026

Balance Sheet
May 31, 2026

ACCOUNT DESCRIPTION	GENERAL FUND	SERIES 2015 DEBT SERVICE FUND	TOTAL
<u>ASSETS</u>			
Cash - Checking Account	\$ 542,387	\$ -	\$ 542,387
Cash On Hand/Petty Cash	500	-	500
Due From Other Funds	-	3,546	3,546
Investments:			
Money Market Account	3,136,726	-	3,136,726
SBA Account	419,596	-	419,596
SBA Account Reserves	439,677	-	439,677
Interest Account	-	16	16
Principal	-	69	69
Redemption Fund	-	27,236	27,236
Reserve Fund	-	254,532	254,532
Revenue Fund	-	401,946	401,946
Prepaid Items	3,008	-	3,008
Deposits	9,828	-	9,828
TOTAL ASSETS	\$ 4,551,722	\$ 687,345	\$ 5,239,067
<u>LIABILITIES</u>			
Accounts Payable	\$ 157,233	\$ -	\$ 157,233
Accrued Expenses	175	-	175
Due To Other Funds	3,546	-	3,546
TOTAL LIABILITIES	160,954	-	160,954

Balance Sheet
May 31, 2026

ACCOUNT DESCRIPTION	GENERAL FUND	SERIES 2015 DEBT SERVICE FUND	TOTAL
FUND BALANCES			
Nonspendable:			
Prepaid Items	3,008	-	3,008
Deposits	9,828	-	9,828
Restricted for:			
Debt Service	-	687,345	687,345
Assigned to:			
Operating Reserves	863,888	-	863,888
Reserves - Clubhouse	76,229	-	76,229
Reserves - Equipment	2,000	-	2,000
Reserves-Gates/Guardhouses	101,506	-	101,506
Reserves - Hurricane	53,000	-	53,000
Reserves - Irrigation System	148,506	-	148,506
Reserves - Landscape	101,506	-	101,506
Reserve - Lighting	50,753	-	50,753
Reserves - Pools	101,506	-	101,506
Reserves - Roads and Sidewalks	203,011	-	203,011
Reserve - Security Features	101,506	-	101,506
Reserves - Wall & Fence Perimeter	84,397	-	84,397
Unassigned:	2,490,124	-	2,490,124
TOTAL FUND BALANCES	\$ 4,390,768	\$ 687,345	\$ 5,078,113
TOTAL LIABILITIES & FUND BALANCES	\$ 4,551,722	\$ 687,345	\$ 5,239,067

Statement of Revenues, Expenditures and Changes in Fund Balances
For the Period Ending May 31, 2026

ACCOUNT DESCRIPTION	ANNUAL ADOPTED BUDGET	YEAR TO DATE BUDGET	YEAR TO DATE ACTUAL	VARIANCE (\$) FAV(UNFAV)	YTD ACTUAL AS A % OF ADOPTED BUD	MAY-26 ACTUAL
REVENUES						
Interest - Investments	\$ -	\$ -	\$ 87,956	\$ 87,956	0.00%	\$ 12,129
Room Rentals	-	-	200	200	0.00%	-
Interest - Tax Collector	-	-	5,662	5,662	0.00%	-
Rental Income	-	-	800	800	0.00%	200
Membership Cards	-	-	270	270	0.00%	150
Special Assmnts- Tax Collector	3,458,046	3,415,565	3,433,032	17,467	99.28%	10,825
Decal headlamp/windshield	-	-	6,842	6,842	0.00%	1,350
Other Miscellaneous Revenues	-	-	19,680	19,680	0.00%	13,808
Insurance Reimbursements	-	-	11,293	11,293	0.00%	-
TOTAL REVENUES	3,458,046	3,415,565	3,565,735	150,170	103.11%	38,462

EXPENDITURES

Administration

ProfServ-Arbitrage Rebate	1,800	-	1,200	(1,200)	66.67%	-
ProfServ-Dissemination Agent	1,800	-	-	-	0.00%	-
ProfServ-Engineering	91,491	60,994	48,931	12,063	53.48%	7,097
ProfServ-Mgmt Consulting	77,596	51,731	51,731	-	66.67%	6,466
ProfServ-Property Appraiser	2,222	2,222	2,222	-	100.00%	-
ProfServ-Trustee Fees	9,756	9,756	5,000	4,756	51.25%	5,000
Attorney Fees	52,749	35,166	51,755	(16,589)	98.12%	11,825
ProfServ-Web Site Maintenance	5,000	3,333	1,553	1,780	31.06%	-
Auditing Services	4,400	4,400	4,500	(100)	102.27%	-
Onsite Maintenance	135,142	90,095	-	90,095	0.00%	-
Onsite Property Manager	170,609	113,739	254,536	(140,797)	149.19%	23,621
Attendant	118,487	78,991	-	78,991	0.00%	-
Security	433,763	289,175	299,139	(9,964)	68.96%	36,761
Postage and Freight	246	164	322	(158)	130.89%	57
Rentals & Leases	2,400	1,600	-	1,600	0.00%	-
Insurance - Property	49,525	49,525	49,525	-	100.00%	-
Insurance	8,772	8,772	9,447	(675)	107.69%	-
Legal Advertising	475	317	137	180	28.84%	-
Other Current Charges	3,681	2,454	4,575	(2,121)	124.29%	1,075
Dues, Licenses, Subscriptions	2,835	1,890	5,301	(3,411)	186.98%	90
Total Administration	1,172,749	804,324	789,874	14,450	67.35%	91,992

Maintenance: Gate/Fence

R&M-Fence	48,745	32,497	8,700	23,797	17.85%	-
R&M-Gate	40,109	26,739	42,322	(15,583)	105.52%	477
R&M-Access&Surveillance Systems	2,212	1,475	14,915	(13,440)	674.28%	-

Statement of Revenues, Expenditures and Changes in Fund Balances
For the Period Ending May 31, 2026

ACCOUNT DESCRIPTION	ANNUAL ADOPTED BUDGET	YEAR TO DATE BUDGET	YEAR TO DATE ACTUAL	VARIANCE (\$) FAV(UNFAV)	YTD ACTUAL AS A % OF ADOPTED BUD	MAY-26 ACTUAL
Gate Transponders	914	609	-	609	0.00%	-
Misc-Contingency	30,000	20,000	-	20,000	0.00%	-
Total Maintenance: Gate/Fence	121,980	81,320	65,937	15,383	54.06%	477
<u>Maintenance: Lakes</u>						
R&M-Pump Station	13,703	9,135	19,142	(10,007)	139.69%	213
Lake & Wetlands Maintenance	114,562	76,375	56,228	20,147	49.08%	5,595
Pest Control-Midge Lake Banks	30,542	20,361	22,190	(1,829)	72.65%	2,774
Mitigation Maintenance	12,800	8,533	-	8,533	0.00%	-
Mitigation Reporting	1,500	1,000	-	1,000	0.00%	-
Misc-Contingency	32,547	21,699	-	21,699	0.00%	-
Total Maintenance: Lakes	205,654	137,103	97,560	39,543	47.44%	8,582
<u>Maintenance: Landscape/Hardscape</u>						
R&M-Mulch	51,567	34,378	-	34,378	0.00%	-
R&M-Pest Control	133,443	88,962	93,952	(4,990)	70.41%	4,160
R&M-Trees and Trimming	12,983	8,681	10,984	(2,303)	84.60%	-
Royal Palm Treatment	2,428	1,619	-	1,619	0.00%	-
R&M-Pressure Washing	37,300	24,867	48,713	(23,846)	130.60%	5,900
Rust Control	20,917	13,945	11,779	2,166	56.31%	1,472
Landscape Maintenance	803,603	535,735	318,514	217,221	39.64%	39,457
Landscape Replacement	178,750	119,167	9,590	109,577	5.37%	-
Landscape Replacement-Annuals	11,146	7,431	-	7,431	0.00%	-
Irrigation Maintenance	87,145	58,097	52,154	5,943	59.85%	6,519
Irrigation Repairs & Replacement	94,921	63,281	84,664	(21,383)	89.19%	2,794
Total Maintenance: Landscape/Hardscape	1,434,203	956,163	630,350	325,813	43.95%	60,302
<u>Maintenance: Pool</u>						
R&M-Pools	29,993	19,995	13,828	6,167	46.10%	1,690
Pool Furniture	1,275	850	-	850	0.00%	-
Pool Permits	600	600	-	600	0.00%	-
Total Maintenance: Pool	31,868	21,445	13,828	7,617	43.39%	1,690
<u>Maintenance: Other</u>						
Gym Equipment Maintenance	3,338	2,225	3,148	(923)	94.31%	344
R&M-General	69,934	46,623	719,633	(673,010)	1029.02%	507,456
Janitorial Maintenance	70,033	46,689	113	46,576	0.16%	-
R&M - Water Feature	6,268	4,179	1,925	2,254	30.71%	275
IT Maintenance	2,473	1,649	1,050	599	42.46%	525
A/C Maintenance	5,476	3,651	2,852	799	52.08%	567
Total Maintenance: Other	157,522	105,016	728,721	(623,705)	462.62%	509,167

Statement of Revenues, Expenditures and Changes in Fund Balances
For the Period Ending May 31, 2026

ACCOUNT DESCRIPTION	ANNUAL ADOPTED BUDGET	YEAR TO DATE BUDGET	YEAR TO DATE ACTUAL	VARIANCE (\$) FAV(UNFAV)	YTD ACTUAL AS A % OF ADOPTED BUD	MAY-26 ACTUAL
Utilities						
Communication - Telephone	22,483	14,989	22,065	(7,076)	98.14%	3,733
Electricity - Entrance	15,380	10,253	6,052	4,201	39.35%	820
Electricity - Pump Station	58,692	39,128	38,616	512	65.79%	4,727
Electricity - Streetlights	133,832	89,221	94,047	(4,826)	70.27%	9,531
Utility - Water	5,309	3,539	5,133	(1,594)	96.68%	729
Utility - Refuse Removal	9,331	6,221	6,275	(54)	67.25%	800
Electric - Monuments	367	245	261	(16)	71.12%	34
Electricity	21,361	14,241	16,070	(1,829)	75.23%	2,195
Total Utilities	266,755	177,837	188,519	(10,682)	70.67%	22,569
Other Expenses						
Fire Alarm Monitoring	1,879	1,879	3,260	(1,381)	173.50%	2,540
Contracts-Fire Exting. Insp.	615	615	623	(8)	101.30%	-
Lease - Copier	4,279	2,853	1,380	1,473	32.25%	69
Golf Cart	1,257	838	4,898	(4,060)	389.66%	1,268
Backflow Assembly Testing	162	162	-	162	0.00%	-
Gym Wipes	3,713	2,475	2,601	(126)	70.05%	130
Misc-Holiday Lighting	20,141	20,141	-	20,141	0.00%	-
Special Events	1,283	855	-	855	0.00%	-
Misc-Licenses & Permits	793	793	-	793	0.00%	-
Entry System-Key Fob	5,750	3,833	11,316	(7,483)	196.80%	-
Office Supplies	13,058	8,705	4,758	3,947	36.44%	185
Op Supplies - Clubhouse	498	332	-	332	0.00%	-
Food and Beverage	563	375	244	131	43.34%	22
Cleaning Supplies	9,881	6,587	4,924	1,663	49.83%	1,481
Water Cooler	1,459	972	1,490	(518)	102.12%	-
Electrical Supplies	1,361	907	-	907	0.00%	-
Reserve - Equipment	623	-	-	-	0.00%	-
Total Other Expenses	67,315	52,322	35,494	16,828	52.73%	5,695
TOTAL EXPENDITURES	3,458,046	2,335,530	2,550,283	(214,753)	73.75%	700,474
Excess (deficiency) of revenues Over (under) expenditures	-	1,080,035	1,015,452	(64,583)	0.00%	(662,012)
Net change in fund balance	\$ -	\$ 1,080,035	\$ 1,015,452	\$ (64,583)	0.00%	\$ (662,012)
FUND BALANCE, BEGINNING (OCT 1, 2025)	3,375,316	3,375,316	3,375,316			
FUND BALANCE, ENDING	\$ 3,375,316	\$ 4,455,351	\$ 4,390,768			

**Monterra
Community Development District**

Supporting Schedules

May 31, 2026

Cash and Investment Report
May 31, 2026

<u>Investment Type</u>	<u>Bank Name</u>	<u>Maturity</u>	<u>Yield</u>	<u>Balance</u>
<u>General Fund</u>				
Checking Account - Operating #6534	Truist	N/A	1.55%	\$ 10,312
Checking Account - Operating #2407	Bank United	N/A	0.00%	532,076 (1)
			Subtotal Checking	<u>542,388</u>
Money Market #4674	Bank United	N/A	3.40%	3,136,726
SBA Excess Funds #2511	Florida Prime	N/A	3.81%	419,596
SBA Capital Reserve #2400	Florida Prime	N/A	3.81%	439,677
			Subtotal SBA	<u>3,995,999</u>
			GF Subtotal	<u>4,538,387</u>
 <u>Investment Type</u>				
<u>Debit Service</u>				
<u>Fund 202</u>				
2015 Series Interest account #5102S	Wells Fargo	N/A	0.06%	16
2015 Series Principal account #5101S	Wells Fargo	N/A	0.06%	69
2015 Series Redemption account #5105S	Wells Fargo	N/A	0.06%	27,236
2015 Series Reserve fund #5104S	Wells Fargo	N/A	0.06%	254,532
2015 Series Revenue account #5100S	Wells Fargo	N/A	0.06%	401,946
			Total Fund 202	<u>683,799</u>
			Grand Total	<u><u>\$ 5,222,186</u></u>

Note(s):

1) Transferring \$3.5K to trustee (Wells Fargo) for debt service in June.

Statement of Revenues, Expenditures and Changes in Fund Balances
For the Period Ending May 31, 2026

Account Description	Oct Actual	Nov Actual	Dec Actual	Jan Actual	Feb Actual	Mar Actual	Apr Actual	May Actual	YTD Total
Total Revenues	14,676	571,402	2,560,610	85,686	86,317	76,316	132,264	38,464	3,565,735
<u>Expenditures</u>									
Administrative	71,412	28,092	8,869	11,013	14,106	19,065	6,768	25,144	184,469
Property management and security	71,713	42,415	91,931	47,085	108,426	71,544	105,443	66,848	605,405
Maintenance: Gate/Fence	4,187	8,998	4,381	6,275	9,912	18,475	13,230	479	65,937
Maintenance: Lakes	43,772	(18,343)	4,369	8,970	8,970	14,770	26,470	8,582	97,560
Maintenance: Landscape/Hardscape	78,182	67,810	139,791	69,933	74,405	72,063	67,863	60,303	630,350
Maintenance: Pool	1,566	1,750	1,540	2,305	1,847	1,568	1,562	1,690	13,828
Maintenance: Other	27,983	33,185	4,107	15,636	48,906	32,750	56,988	509,166	728,721
Utilities	19,946	26,535	23,001	24,299	24,354	24,440	23,375	22,569	188,519
Other Expenses	37	4,962	3,906	2,336	4,389	4,856	9,311	5,697	35,494
Total Expenditures	318,798	195,404	281,895	187,852	295,315	259,531	311,010	700,478	2,550,283
Excess (deficiency) of revenues Over (under) expenditures	(304,122)	375,998	2,278,715	(102,166)	(208,998)	(183,215)	(178,746)	(662,014)	1,015,452

MONTERRA
Community Development District

Payment Register by Bank Account

For the Period from 05/01/26 to 05/31/26

(Sorted by Check / ACH No.)

Date	Payee Type	Payee	Invoice No.	Payment Description	Invoice / GL Description	GL Account #	Amount Paid	
<u>BANKUNITED, N.A. - (ACCT#XXXXX2407)</u>								
ACH #100703								
05/06/26	Vendor	AMAZON CAPITAL SERVICES	1VDQ-JMV9-9KP7	Pool Handrail Cover	R&M-Pools	001-546074-53965	\$21.84	
							ACH Total	<u>\$21.84</u>
ACH #100704								
05/06/26	Vendor	L.A. RUST, INC	738056	May 26 Mthly Rust Control	Rust Control	001-546193-53960	\$500.00	
							ACH Total	<u>\$500.00</u>
ACH #100705								
05/06/26	Vendor	Total Entry Control	46479	Swing Gate repair	R&M-Gate	001-546034-53950	\$875.99	
05/06/26	Vendor	Total Entry Control	46360	Univ. Dr barrier gate system - final payment	University Dr Replacement Final payment	001-546034-53950	\$4,996.37	
							ACH Total	<u>\$5,872.36</u>
ACH #100706								
05/06/26	Vendor	ODP BUSINESS SOLUTIONS, LLC	466888851001	Janitorial Supplies	Cleaning Supplies	001-552077-53980	\$386.78	
							ACH Total	<u>\$386.78</u>
ACH #100707								
05/06/26	Vendor	SPECIALIZED INTEGRATED SOLUTIONS, INC	R7106	April 26 LONG RANGE RADIO MONITORING APR 2026	LONG RANGE RADIO MONITORING APR 2026	001-546001-53970	\$39.95	
							ACH Total	<u>\$39.95</u>
ACH #100708								
05/06/26	Vendor	SOUTHERN GOLF CARS INC	RE-E102-00473-11	May 26 golf cart rental	Golf Cart	001-546196-53980	\$500.00	
							ACH Total	<u>\$500.00</u>
ACH #100709								
05/06/26	Vendor	INFRAMARK LLC	178530	May 26 Prop Mgt, Onsite and Records Fees	May 26 Admin Fees	001-531027-51320	\$6,466.33	
05/06/26	Vendor	INFRAMARK LLC	178530	May 26 Prop Mgt, Onsite and Records Fees	May 26 Records Storage Fee	001-549901-51302	\$120.00	
05/06/26	Vendor	INFRAMARK LLC	178530	May 26 Prop Mgt, Onsite and Records Fees	May 26 Onsite Management Svs	001-534201-51320	\$23,620.75	
							ACH Total	<u>\$30,207.08</u>
ACH #100710								
05/06/26	Vendor	5 STAR POOLS INC	72524	May 26 Pool & Splash Pad Svs	Mthly Pool & Splash Pad Svs	001-546074-53965	\$1,540.00	
05/06/26	Vendor	5 STAR POOLS INC	72553	May 26 Fountain Svs	Mthly Fountain Svs	001-546191-53970	\$275.00	
							ACH Total	<u>\$1,815.00</u>
ACH #100711								
05/06/26	Vendor	Southern Plant and Pest Services	04292026MONTCLUB	April 26 Clubhouse Pest Control	clubhouse pest control	001-546070-53960	\$65.00	
05/06/26	Vendor	Southern Plant and Pest Services	04272026EMONT	April 26 Pest Control	R&M-Pest Control	001-546070-53960	\$8,625.00	
05/06/26	Vendor	Southern Plant and Pest Services	04302026MONTBEES	Bee Hive Removal	R&M-Pest Control	001-546070-53960	\$325.00	
							ACH Total	<u>\$9,015.00</u>

MONTERRA
Community Development District

Payment Register by Bank Account

For the Period from 05/01/26 to 05/31/26

(Sorted by Check / ACH No.)

Date	Payee Type	Payee	Invoice No.	Payment Description	Invoice / GL Description	GL Account #	Amount Paid
ACH #100712							
05/06/26	Vendor	People's Choice Pressure Cleaning	19634	April 26 Pressure washing	R&M-Pressure Washing	001-546171-53960	\$5,900.00
ACH Total							<u>\$5,900.00</u>
ACH #100713							
05/06/26	Vendor	UNIFIED TECHNOLOGY GROUP, LLC	INV-099501	Vertilink May-July 2026	VLL AMENITIES MAY TO JULY 2026	001-546192-53970	\$525.00
ACH Total							<u>\$525.00</u>
ACH #100714							
05/06/26	Vendor	CREATIVE NORTH, INC.	05MMMCDD	May 26 Mthly Irr Maintenance	IRR MONTHLY MAINTENANCE May 26	001-546930-53960	\$6,519.19
05/06/26	Vendor	CREATIVE NORTH, INC.	MCDD07744	April Irrigation Repairs	Irrigation Repairs & Replacement	001-546932-53960	\$489.78
ACH Total							<u>\$7,008.97</u>
ACH #100715							
05/14/26	Vendor	COASTAL WASTE & RECYCLING INC	WW0001713928	May 26 Refuse removal	REFUSE REMOVAL May 26	001-543020-53975	\$800.46
ACH Total							<u>\$800.46</u>
ACH #100716							
05/14/26	Vendor	M&M ASPHALT MAINTENANCE INC	097703	Road Resurfacing	R&M-General	001-546001-53970	\$504,954.75
ACH Total							<u>\$504,954.75</u>
ACH #100717							
05/14/26	Vendor	KENT SECURITY OF PALM BEACH, INC.	20041933	May 26 Monthly Billing	MONTHLY BILLING - May 2026	001-534203-51320	\$35,080.00
ACH Total							<u>\$35,080.00</u>
ACH #100718							
05/14/26	Vendor	WAYNE AUTOMATIC	1311078	fire alarm system repairs	Fire Alarm Monitoring	001-531082-53980	\$2,540.00
ACH Total							<u>\$2,540.00</u>
ACH #100719							
05/14/26	Vendor	ODP BUSINESS SOLUTIONS, LLC	466040955001	Janitorial Supplies	Cleaning Supplies	001-552077-53980	\$17.99
05/14/26	Vendor	ODP BUSINESS SOLUTIONS, LLC	466039437001	Janitorial Supplies	Cleaning Supplies	001-552077-53980	\$175.06
05/14/26	Vendor	ODP BUSINESS SOLUTIONS, LLC	466040954001	Janitorial Supplies	Cleaning Supplies	001-552077-53980	\$106.72
05/14/26	Vendor	ODP BUSINESS SOLUTIONS, LLC	466040965001	Janitorial Supplies	Cleaning Supplies	001-552077-53980	\$20.69
05/14/26	Vendor	ODP BUSINESS SOLUTIONS, LLC	466888851002	OFFICE SUPPLIES	Office Supplies	001-551002-53980	\$11.59
05/14/26	Vendor	ODP BUSINESS SOLUTIONS, LLC	466890462001	Janitorial Supplies	Cleaning Supplies	001-552077-53980	\$4.79
05/14/26	Vendor	ODP BUSINESS SOLUTIONS, LLC	468843248001	Dog waste bags	Cleaning Supplies	001-552077-53980	\$97.08
05/14/26	Vendor	ODP BUSINESS SOLUTIONS, LLC	468843280001	Janitorial Supplies	Cleaning Supplies	001-552077-53980	\$48.14
ACH Total							<u>\$482.06</u>
ACH #100720							
05/14/26	Vendor	SPECIALIZED INTEGRATED SOLUTIONS, INC	R7257	May 26 Long range monitoring	Long range radio monitoring 260501-260531	001-546001-53970	\$79.90
ACH Total							<u>\$79.90</u>

MONTERRA
Community Development District

Payment Register by Bank Account

For the Period from 05/01/26 to 05/31/26

(Sorted by Check / ACH No.)

Date	Payee Type	Payee	Invoice No.	Payment Description	Invoice / GL Description	GL Account #	Amount Paid
ACH #100721							
05/14/26	Vendor	HD SUPPLY FACILITIES MAINTENANCE, LTD.	9241687479	light bulbs	Cleaning Supplies	001-552077-53980	\$214.85
ACH Total							\$214.85
ACH #100722							
05/14/26	Vendor	AMAZON CAPITAL SERVICES	1NHV-JXVH-DDDD	Replacement soap dispenser	replacement under sink soap dispenser	001-546001-53970	\$63.96
05/14/26	Vendor	AMAZON CAPITAL SERVICES	17P7-93VJ-MTKN	Tool Set for Maintenance	R&M-General	001-546001-53970	\$143.98
05/14/26	Vendor	AMAZON CAPITAL SERVICES	1LKK-MNNH-RLL7	Cleaning Supplies/gym wipes/bottled water	Cleaning/Janitorial supplies	001-552077-53980	\$120.87
05/14/26	Vendor	AMAZON CAPITAL SERVICES	1LKK-MNNH-RLL7	Cleaning Supplies/gym wipes/bottled water	Gym Wipes	001-546961-53980	\$145.97
05/14/26	Vendor	AMAZON CAPITAL SERVICES	1LKK-MNNH-RLL7	Cleaning Supplies/gym wipes/bottled water	bottled water	001-552076-53980	\$21.98
05/14/26	Vendor	AMAZON CAPITAL SERVICES	1FJ4-6KLR-LMM6	landscaping supplies	Landscape Maintenance	001-546300-53960	\$87.46
ACH Total							\$584.22
ACH #100723							
05/14/26	Vendor	Southern Plant and Pest Services	05052026MONTPAVERS	May 26 monthly weed control	R&M-Pest Control	001-546070-53960	\$667.50
05/14/26	Vendor	Southern Plant and Pest Services	05072026MONTBEES	honey bee removal - Pine Island	Honey Bee removal Pine Island	001-546070-53960	\$250.00
ACH Total							\$917.50
ACH #100724							
05/15/26	Vendor	Southern Plant and Pest Services	05082026MONTMOSQ	May 26 Mosquito control	MOSQUITO CONTROL - VARIOUS AREAS	001-546070-53960	\$1,037.94
ACH Total							\$1,037.94
ACH #100725							
05/20/26	Vendor	REDLINE IGUANA REMOVAL, LLC	14869	May 26 monthly iguana removal	PEST CONTROL	001-546070-53960	\$1,250.00
ACH Total							\$1,250.00
ACH #100726							
05/20/26	Vendor	BILLING COCHRAN, P.A.	198531	Apr 26 Legal Svs	ATTORNEY SERVICES	001-531058-51302	\$11,825.00
ACH Total							\$11,825.00
ACH #100727							
05/20/26	Vendor	SOUTHERN GOLF CARS INC	S213177	golf Car brake repairs	golf Car brake repairs	001-546196-53980	\$619.00
05/20/26	Vendor	SOUTHERN GOLF CARS INC	S213460	Golf Car Repair	Golf Cart	001-546196-53980	\$149.00
ACH Total							\$768.00
ACH #100728							
05/20/26	Vendor	FedEx	9-283-49282	FedEx expenses	FEDEX CHARGES	001-541006-51302	\$57.30
ACH Total							\$57.30
ACH #100729							
05/20/26	Vendor	RUST TECH SERVICES, INC.	099474	May 26 Rust control	Rust Control Svs May 26	001-546193-53960	\$972.41
ACH Total							\$972.41

MONTERRA
Community Development District

Payment Register by Bank Account

For the Period from 05/01/26 to 05/31/26

(Sorted by Check / ACH No.)

Date	Payee Type	Payee	Invoice No.	Payment Description	Invoice / GL Description	G/L Account #	Amount Paid
ACH #100730							
05/20/26	Vendor	MILLER, LEGG & ASSOCIATES, INC	06MLA00168.2025-333	Eng svs April 26	Engineering Svs - Apr 26	001-531013-51302	\$1,170.00
05/20/26	Vendor	MILLER, LEGG & ASSOCIATES, INC	06MLA00168.2025-334	Eng Svs April 26	FOR PROFESSIONAL SERVICES: April 26	001-531013-51302	\$585.00
05/20/26	Vendor	MILLER, LEGG & ASSOCIATES, INC	06MLA00168.2025-335	Engineering Svs April 26	FOR PROFESSIONAL SERVICES: April 26	001-531013-51302	\$438.75
05/20/26	Vendor	MILLER, LEGG & ASSOCIATES, INC	06MLA00168.2025-336	Engineering Svs - April 26	FOR PROFESSIONAL SERVICES: April 26	001-531013-51302	\$4,903.05
ACH Total							\$7,096.80
ACH #100731							
05/20/26	Vendor	INFRAMARK LLC	179201	Comcast mobile/Printer supplies - 03/20/26	comcast / printer supplies	001-549901-51302	\$831.24
ACH Total							\$831.24
ACH #100732							
05/20/26	Vendor	Southern Plant and Pest Services	05122026ONTMIDGE	Midge Control	Midge Control - various areas	001-546367-53955	\$2,773.80
05/20/26	Vendor	Southern Plant and Pest Services	05152026MONTBEEES	bee hive removal	bee hive removal - AT&T box	001-546070-53960	\$225.00
ACH Total							\$2,998.80
ACH #100733							
05/20/26	Vendor	CREATIVE NORTH, INC.	MCDD07870	replaced damaged valve	Irr repairs - VDS	001-546932-53960	\$928.58
ACH Total							\$928.58
ACH #100734							
05/27/26	Vendor	AMAZON CAPITAL SERVICES	1T6F-QTHT-WJRY	office chair/exterior paint supplies	OFFICE CHAIR	001-551002-53980	\$151.99
05/27/26	Vendor	AMAZON CAPITAL SERVICES	1T6F-QTHT-WJRY	office chair/exterior paint supplies	Painting supplies	001-534200-51320	\$166.10
ACH Total							\$318.09
ACH #100735							
05/27/26	Vendor	SPECIALIZED INTEGRATED SOLUTIONS, INC	R7034	Long range monitoring - 04/01 - 06/30/26	Long range monitoring	001-546001-53970	\$109.80
ACH Total							\$109.80
CHECK # 1232							
05/19/26	Vendor	Total Entry Control	46354AA	Pine Island Gate system replacement	R&M-Access&Surveillance Systems	001-546349-53950	\$12,429.44
Check Total							\$12,429.44
ACH #300179							
05/12/26	Vendor	City of Cooper City	051126-1457-ACH	SVC PRD 04/07-05/07/2026	WATER & SEWER	001-543018-53975	\$608.30
ACH Total							\$608.30
ACH #DD1083							
05/04/26	Vendor	COMCAST	040226-9407-ACH-A	SVC PRD 04/01-04/30/2026	Communication - Telephone	001-541003-53975	\$470.55
ACH Total							\$470.55

MONTERRA
Community Development District

Payment Register by Bank Account

For the Period from 05/01/26 to 05/31/26

(Sorted by Check / ACH No.)

Date	Payee Type	Payee	Invoice No.	Payment Description	Invoice / GL Description	G/L Account #	Amount Paid	
ACH #DD1084								
05/04/26	Vendor	COMCAST	042726-6762-ACH-A	SVC PRD 05/01-05/31/2026	8495 75 266 0316762	001-541003-53975	\$821.60	
							ACH Total	<u>\$821.60</u>
							Account Total	<u><u>\$649,969.57</u></u>

TRUIST BANK - (ACCT#XXXXX6534)

ACH #DD420								
05/06/26	Vendor	TRUIST BANK	041126-8002-ACH	supplies/repairs/food	HOME DEPOT	001-546001-53970	\$132.82	
05/06/26	Vendor	TRUIST BANK	041126-8002-ACH	supplies/repairs/food	SPEEDWAY	001-549901-51302	\$17.77	
05/06/26	Vendor	TRUIST BANK	041126-8002-ACH	supplies/repairs/food	MICROSOFT	001-554020-51302	\$90.00	
05/06/26	Vendor	TRUIST BANK	041126-8002-ACH	supplies/repairs/food	OFFICE SUPPLIES	001-551002-53980	\$21.39	
05/06/26	Vendor	TRUIST BANK	041126-8002-ACH	supplies/repairs/food	LOWES	001-546001-53970	\$14.94	
							ACH Total	<u>\$276.92</u>
							Account Total	<u><u>\$276.92</u></u>

Total Amount Paid	\$650,246.49
--------------------------	---------------------

MEMORANDUM

TO: District Manager

FROM: Billing Cochran, P.A.
District Counsel

DATE: June 11, 2026

RE: 2026 Legislative Update

As District Counsel, throughout the year we continuously monitor pending legislation that may be applicable to the governance and operation of our Community Development District and other Special District clients. It is at this time of year that we summarize those legislative acts that have become law during the most recent legislative session, as follows:

1. Chapter [TBD], Laws of Florida (HB 0145). This legislation amends the sovereign-immunity statute to raise liability caps and change tort-claim procedures for government entities. The bill revises Section 768.28, Florida Statutes, increasing the statutory limits on damages recoverable against the state and its agencies/subdivisions (including special districts). For causes of action accruing on or after October 1, 2026, the liability caps increase from \$200,000 to \$350,000 per person and from \$300,000 to \$500,000 per incident. The bill also authorizes state agencies and subdivisions to settle claims or judgments in excess of those caps, up to available insurance limits, without requiring a legislative claims bill.

The bill authorizes a state subdivision (e.g. counties, municipalities, special districts including CDDs) to settle a claim or judgment in excess of the statutory cap without requiring a separate legislative claim bill, so long as settlement is within insurance coverage limits. The bill prohibits any insurance policy issued on or after October 1, 2026, from conditioning liability coverage or payment on the later enactment of a legislative claim bill.

In addition, the bill shortens the pre-suit notice period by requiring claimants to present a claim to the appropriate agency within 18 months after accrual of the claim, rather than the current three-year period. It also revises the statute of limitations by requiring most negligence actions against governmental entities to be filed within two (2) years, while maintaining existing limitations periods for medical malpractice, wrongful death, and contribution claims. The bill also reduces the time for an agency or the Department of Financial Services to make a final disposition of a claim before it is deemed denied, from six (6) months to four (4) months.

This law applies directly to CDDs because CDDs are among the “subdivisions” of state government covered by section 768.28, Florida Statutes. As such CDDs may now be subject to higher damage awards for tort claims.

2. Chapter [TBD], Laws of Florida (HB 273). This legislation revises Florida law governing state financial assistance and rural economic development programs to include certain

special districts and improve payment processing for eligible rural entities. The bill amends Section 215.971, Florida Statutes to allow state agencies, under certain conditions, to directly facilitate or expedite payment of invoices for counties, municipalities, and qualifying special districts, particularly those located in rural areas or designated rural areas of opportunity. It authorizes agencies to structure agreements so that eligible rural governments and certain special districts, especially those providing water and wastewater services, receive faster payment processing for verified, completed work. The intent is to reduce financial strain and cash flow challenges that rural entities often face when administering state-funded projects, while preserving existing legal and regulatory requirements. The legislation also amends Section 288.0656, Florida Statutes to expand the definition of “rural community” to explicitly include independent special districts that provide water and wastewater services within rural areas of opportunity. This expansion makes those districts eligible for rural economic development support programs and related state assistance. The act takes effect July 1, 2026.

This legislation applies CDDs in a limited and conditional way, depending on the type of CDD and the services it provides. CDDs that are involved in state-funded infrastructure projects, such as water, wastewater, drainage, or utility improvements, may benefit from the amendment to Section 215.971, Florida Statutes. If a CDD is acting as a recipient or sub recipient of state financial assistance, the law allows state agencies to structure agreements so that invoices can be processed and paid more quickly for verified work. This can improve cash flow for CDDs building infrastructure, particularly smaller or rural CDDs that rely on this type of reimbursement funding. Second, the bill’s expansion of the definition of “rural community” under Section 288.0656, Florida Statutes generally does not directly include most CDDs, because eligibility is tied primarily to counties, municipalities, and independent special districts providing water and wastewater services in rural areas of opportunity. A typical CDD would only benefit if it meets those narrow conditions, meaning it operates in a qualifying rural area and functions in a way that aligns with the statutory definition (or is structured similarly to an independent utility-focused district).

3. Chapter [TBD], Laws of Florida (HB 0655). This legislation creates a new exemption under Florida law (Section 70.90, Florida Statutes) that allows agencies to hold closed attorney-client meetings during the 90-day notice period for claims brought under the Bert J. Harris, Jr., Private Property Rights Protection Act. These closed meetings are limited to discussions between the agency and its attorney for purposes of settlement strategy or negotiation of private property rights claims. While the meetings are exempt from Florida’s Sunshine Law, they must still be recorded by a certified court reporter, fully transcribed, and later released as a public record once the claim is resolved or the statute of limitations expires if no settlement or litigation occurs.

The law also creates a temporary public records exemption for the transcripts, recordings, minutes, and related materials generated during these closed sessions, ensuring confidentiality during active negotiations. However, this exemption is not permanent; it is subject to future legislative review and sunsets in 2031 unless reenacted. The act takes effect July 1, 2026.

The law allows a CDD Board of Supervisors to hold closed attorney-client sessions when the CDD is facing a pre-suit claim under the Bert J. Harris, Jr., Private Property Rights Protection Act regarding topics such as land use impacts, infrastructure construction, easement disputes, and development-related claims that can trigger property rights assertions under the Bert Harris Act.

During these closed sessions, the CDD can privately discuss settlement strategy with its attorney without public disclosure of sensitive legal positions. However, the exemption is narrow and procedural. The CDD must still provide public notice of the meeting, the session must begin and end in an open meeting, and a certified court reporter must record everything discussed. Although the discussion is confidential at the time, the transcript becomes a public record once the claim is resolved or the statutory timeframe expires if no settlement or lawsuit is filed.

4. Chapter 2026-115, Laws of Florida (HB 1085). This legislation creates the Local Government Cybersecurity Protection Program within the Florida Digital Service to assist local governments in strengthening cybersecurity defenses, particularly against threats such as ransomware. It establishes a statewide grant and procurement program that allows eligible local governments to access cybersecurity-related information technology commodities and services through contracts managed by the Florida Digital Service, with a preference for fiscally constrained counties. The program also requires data-sharing agreements between the state and participating local governments to support threat detection, prevention, and incident response.

Local governments may either apply for grants or independently purchase cybersecurity services through state-negotiated contracts, though the local government remains responsible for any associated costs. The law further requires annual reporting to the Governor and Legislature on program participation, funding, and outcomes, ensuring oversight and transparency. The program is set to operate through 2031 unless reenacted. The act takes effect July 1, 2026.

This law applies to CDDs because CDDs are local governments for many operational purposes, including infrastructure, procurement, and administrative functions, and therefore fall within the category of eligible participants under the Local Government Cybersecurity Protection Program. CDDs would be able to access state-negotiated cybersecurity contracts and services through the Florida Digital Service to improve protection of district systems. Even if a CDD does not apply for a cybersecurity grant, it may still purchase cybersecurity commodities and services through the state contracts, which could help reduce costs and improve security standards. However, participation is optional rather than mandatory, and CDDs remain responsible for all costs associated with any purchases or services obtained under the program.

5. Chapter [TBD], Laws of Florida (SB 1180). This legislation makes several targeted but significant changes to the law governing CDDs under Chapter 190, Florida Statutes, with the most important impact being the creation of a formal recall process for elected board members. The bill's primary feature is the creation of a new statutory section establishing a detailed procedure that allows qualified electors within a CDD to remove elected members of the board of supervisors through a recall process. The law limits recall to specific grounds such as malfeasance, misfeasance, neglect of duty, incompetence, drunkenness, permanent inability to perform duties, or conviction of certain felonies. It sets out a structured, multi-step process that begins with a petition signed by at least 10 percent of eligible voters, followed by verification of signatures, the preparation of a formal record of recall proceedings, and then a second petition requiring 15 percent of electors to trigger a recall referendum. If the referendum proceeds, a majority vote determines whether the board member is removed from office, and any resulting vacancy is filled according to existing statutory procedures. The legislation also imposes campaign finance requirements on recall efforts, establishes timelines, governs petition form and verification, allows limited

withdrawal of signatures, and creates penalties for fraud or misconduct in the petition process. In addition to the recall framework, the bill clarifies that CDD board members elected by residents are subject to recall, aligning CDD governance more closely with other forms of local government accountability. It also provides that individuals removed by recall, or who resign after a recall petition is filed, are ineligible for reappointment to the board for two years.

The legislation further revises the definition of “compact, urban, mixed-use district” under Section 190.003, Florida Statutes. The revised definition applies to districts consisting of a maximum of 75 acres located within a municipality and within either a qualified opportunity zone or a community redevelopment area. The amendment clarifies qualifying development thresholds by providing that such districts must include either at least 400,000 square feet of retail development and 500 residential units, or at least 250,000 square feet of commercial development and 500 affordable residential rental units for very-low-income, low-income, or moderate-income persons. This revision is significant for developers because it affects eligibility and structuring considerations for the creation of certain community development districts.

The legislation clarifies that restrictions on local regulation of synthetic turf do not prevent a CDD from enforcing private deed restrictions, preserving a CDD’s ability to uphold community standards through covenants. The act takes effect July 1, 2026.

This law applies directly to CDDs because it creates, for the first time, a formal statutory process that allows residents to recall elected members of a CDD board of supervisors. It introduces clear procedures, thresholds, and legal standards for removal, thereby increasing accountability of board members to district electors. The law also clarifies that CDDs may continue enforcing deed restrictions despite broader limits on local regulation of synthetic turf and updates certain statutory definitions affecting district formation and development. Overall, the most significant impact is the shift toward greater resident oversight and governance accountability within CDDs.

5. Chapter 2026-3, Laws of Florida (SB 290). This legislation revises multiple areas of state law, with a primary focus on agriculture, public safety, contractor regulation, and consumer protection. A significant component of the legislation strengthens contractor and vendor accountability by requiring contractors to pay subcontractors and suppliers within 45 days of receiving payment, or in accordance with contractual terms, and authorizing disciplinary action for noncompliance. Additionally, vendors that default on contracts, fail to pay subcontractors, or demonstrate repeated poor performance may be suspended or barred from public contracting for up to five years.

The bill further clarifies and reinforces how public entities may lawfully spend funds and administer contracts for public purposes. The legislation affirms that public funds may be used for core governmental infrastructure and improvements, such as public buildings, emergency shelters, affordable housing, and energy efficiency projects, thereby helping to define the scope of permissible capital projects and expenditures. At the same time, it places limitations on the use of public funds for certain privately owned facilities, reinforcing the principle that expenditures must primarily serve a valid public purpose rather than confer a disproportionate private benefit. The act takes effect July 1, 2026.

This law applies directly to CDDs because CDDs function as local units of special-purpose government that procure services, manage infrastructure, and enter into public contracts. Since a CDD regularly contracts for construction, maintenance, and infrastructure improvements, the new requirement that contractors timely pay subcontractors and suppliers directly affects how a CDD administers its contracts. In addition, the provisions allowing suspension or disqualification of nonperforming vendors from public contracting are relevant to CDD procurement practices, especially where the district adopts or mirrors state purchasing standards. CDDs routinely finance and construct infrastructure such as roadways, utilities, stormwater systems, and public facilities. Clarifications regarding allowable public expenditures, such as for government buildings, emergency shelters, and infrastructure, help define the scope of permissible CDD projects and may influence how CDDs' structure future capital plans and bond-funded improvements.

Portions of the bill related to consumer protection and fraud prevention, including prohibitions on misrepresentation (such as impersonating officials), have indirect relevance. CDDs and District Management interact with residents, property owners, and contractors, so these provisions reinforce broader legal standards around transparency, proper representation, and avoidance of deceptive practices in district operations.

6. Chapter 2026-7, Laws of Florida (HB 399). This legislation is a comprehensive land use and development reform measure that primarily limits local government discretion in permitting, zoning, and development regulation while promoting consistency, affordability, and predictability in the development process. A central component of the legislation requires that application fees for development permits and orders imposed by counties and municipalities must be directly tied to the actual costs of reviewing and processing applications, must be publicly listed, and may not be based on construction value or project cost, thereby preventing fee structures that scale with development size rather than administrative expense. The act takes effect upon becoming law.

Even though CDDs do not exercise zoning or land use regulatory authority, the law applies to CDDs as infrastructure and service providers within the framework established by counties and municipalities. As a result, the bill's restrictions on local governments, particularly those related to development permitting, zoning, and land development regulations, will shape the regulatory environment in which CDDs plan, finance, and construct infrastructure.

The provisions limiting development application fees to actual administrative costs may reduce overall project costs for developments within CDD boundaries, which can influence the scope and timing of infrastructure financed by the CDD, including roads, utilities, and stormwater systems. Similarly, the requirement for more objective and clearly defined compatibility standards, along with limits on discretionary denials, may create a more predictable entitlement process, allowing CDDs to better coordinate infrastructure planning with approved development timelines and reduce delays that can affect bond issuances or capital improvement programs.

Although Chapter 2026-7 does not directly regulate CDD powers or governance, it significantly affects the local government land use framework that CDDs rely on, thereby affecting development timing, infrastructure planning, financing, and overall project feasibility within district boundaries.

7. Chapter [TBD], Laws of Florida (HB 967). This legislation establishes a clear legislative intent that local governments must accept electronic forms of payment, including credit cards, debit cards, charge cards, and electronic funds transfers, and specifically requires units of local government to offer online payment options. This applies broadly to counties, municipalities, special districts, and other local government entities, as well as constitutional officers such as clerks of court and tax collectors, unless another form of payment is required by law.

The legislation also preserves existing authority allowing local governments to pass along processing fees to users who choose electronic payment methods and confirms that governments are not liable for verifying card validity or available funds when processing such transactions. Importantly, it mandates that if a local government accepts electronic payments, it must also maintain an online system for doing so, reinforcing a statewide push toward digital accessibility and standardized payment options.

This legislation requires CDDs that collect any type of payment, such as fees, user charges, amenity payments, permit-related charges, or other CDD revenues, to offer electronic payment options, including credit cards, debit cards, and electronic funds transfers. It also specifically requires that if a CDD accepts electronic payments at all, it must maintain a system for accepting those payments online, which may require updates to CDD websites, billing platforms, or third-party payment processors. The legislation also allows CDDs to continue passing through processing fees associated with electronic payments (such as credit card convenience fees), and it preserves their ability to require verification of payment validity and sufficient funds. However, it removes discretion in practice by making online payment capability a mandatory feature for any CDD that accepts electronic payments in any form.

For convenience, we have included copies of the legislation referenced in this memorandum. We request that you include this memorandum as part of the agenda packages for upcoming meetings of the governing boards of those special districts in which you serve as the District Manager and this firm serves as District Counsel. For purposes of the agenda package, it is not necessary to include the attached legislation, as we can provide copies to anyone requesting the same. Copies of the referenced legislation are also accessible by visiting this link: <http://laws.flrules.org/>.

Ladner, Elizabeth

From: Peter Pellerito <PPellerito@millerlegg.com>
Sent: Thursday, June 18, 2026 5:22 PM
To: Jason Weinrub; Colin Branson
Cc: Ladner, Elizabeth; Pete Monzon; Keith Schriener; Adelson Georges; Monterra Clubhouse Manager; Dakota Harp; 06-00168 Monterra CDD
Subject: RE: [EXTERNAL] Re: Benches for Basketball/Pickleball courts
Attachments: BLCH-4TRG_SPEC.pdf; BLCH-2TRG_SPEC.pdf

This message is from an external sender. DO NOT CLICK on links or attachments unless you recognize the sender and know the content is safe.

Lynne

Following discussions regarding the bench and bleacher options for the Monterra Pickleball Court Project, the recommended approach is to complete the current permitted improvements and obtain project closeout prior to pursuing any permanent fix mounted spectator seating improvements.

The primary objective is to avoid delays associated with plan revisions, engineering, permitting, and additional inspections that could significantly impact completion of the current project.

Recommended Approach

- Complete all remaining work under the current permit, including grading, sod installation, fence line restoration, acrylic surfacing, and final inspections (in speaking with Colon, assuming no weather delays, end of June to complete)
- Return the existing benches to the District as originally contemplated.
- Do not install permanent bench foundations or anchorage as part of the current permit.
- Obtain final project closeout and approval from the City.
- Place existing benches at end of court for temporary use
- Evaluate spectator seating as a separate follow-up improvement after permit closeout.

Existing Benches

- The existing benches were originally anchored to concrete foundations.
- Permanent installation of the relocated benches would require new concrete pads and anchorage systems.
- Installation of concrete foundations would likely require plan revisions, permitting review, and additional inspections.
- The cost of engineering, foundations, anchorage, and installation is anticipated to exceed the cost of new pre-engineered seating systems.

Preferred Seating Alternative

- Pre-engineered tip-and-roll bleachers are recommended for consideration, and would necessitate CDD preference of size and possibly color section color.

- Refer to attached shop drawing of product manufactured bleachers
 - 15'-3row \$2,482;
 - 15'-2row \$1,938 per website www.jayprosports.com (equipment cost only)
- Portable bleachers provide flexibility for court operations and maintenance.
- Bleachers can be relocated or stored during storm events if necessary.
- Future installation can be completed under a separate minor improvement effort without impacting the current project schedule.
- Permanent secured bleachers are available in the event District deems fixed bleachers are necessary and would necessitate a concrete pad to anchor.

This approach allows the courts to be completed and opened for use without further delay while providing the District flexibility to evaluate and implement a long-term seating solution at a later date.

Please let me know if you have any questions or require additional information

Regards,

Peter Pellerito, P.E.

Sr. Engineer

Miller-Legg

13680 N.W. 5th Street, Suite 200

Sunrise, Florida 33325

d | (954) 628-3616 ○ | (954) 436-7000 c | (239) 410-2394

From: Jason Weinrub <jason.weinrub@monterracdd.com>

Sent: Thursday, June 18, 2026 3:10 PM

To: Peter Pellerito <PPellerito@millerlegg.com>; Colin Branson <colin@synturfintl.com>

Cc: Ladner, Elizabeth <lladner@inframark.com>; Pete Monzon <pete@jdsasphalt.com>; Keith Schriener <kschriener@millerlegg.com>; Adelson Georges <ageorges@kss1.com>; Monterra Clubhouse Manager <clubhousemanager@monterracdd.com>; Dakota Harp <dakota@synturfintl.com>; Daniel Bates <daniel.bates@hfwcompanies.com>; 06-00168 Monterra CDD <06-00168@millerlegg.com>

Subject: RE: [EXTERNAL] Re: Benches for Basketball/Pickleball courts

Peter are you suggesting based on your email below, that we would have to go through additional permitting to make this happen? Please respond ASAP. I have follow ups based on your response

From: Peter Pellerito <PPellerito@millerlegg.com>

Sent: Thursday, June 18, 2026 2:20 PM

To: Colin Branson <colin@synturfintl.com>; Jason Weinrub <jason.weinrub@monterracdd.com>

Cc: Ladner, Elizabeth <lladner@inframark.com>; Pete Monzon <pete@jdsasphalt.com>; Keith Schriener <kschriener@millerlegg.com>; Adelson Georges <ageorges@kss1.com>; Monterra Clubhouse Manager <clubhousemanager@monterracdd.com>; Dakota Harp <dakota@synturfintl.com>; Daniel Bates <daniel.bates@hfwcompanies.com>; 06-00168 Monterra CDD <06-00168@millerlegg.com>

Subject: RE: [EXTERNAL] Re: Benches for Basketball/Pickleball courts

Colon

Thank you for providing the photographs.

Based on the photos, the existing benches are anchored to concrete foundations. Anchoring the relocated benches directly to the asphalt pavement is not recommended, as it is unlikely to provide a sufficiently secure installation and may create long-term maintenance issues associated with pavement cracking, loosening of anchors, and surface deterioration around the bench locations.

It is recommended that the relocated benches be installed on concrete pads. At a minimum, a saw-cut opening should be provided within the asphalt surface and a concrete slab installed at each bench location. The concrete slab should be a minimum of 4 inches thick and extend at least 8 inches beyond the footprint of each bench leg in all directions. Bench anchors should be installed into the concrete slab in accordance with the bench manufacturer's recommendations.

This approach is more consistent with the existing installation and will provide a more durable and maintainable long-term solution.

Please let me know if you have any questions or require additional information

Regards

Peter Pellerito, P.E.

Sr. Engineer

Miller-Legg

13680 N.W. 5th Street, Suite 200

Sunrise, Florida 33325

d | (954) 628-3616 o | (954) 436-7000 c | (239) 410-2394

From: Colin Branson <colin@synturfintl.com>

Sent: Thursday, June 18, 2026 9:03 AM

To: Jason Weinrub <jason.weinrub@monterracdd.com>

Cc: Ladner, Elizabeth <lladner@inframark.com>; Pete Monzon <pete@idsasphalt.com>; Peter Pellerito <PPellerito@millerlegg.com>; Keith Schriener <kschriener@millerlegg.com>; Adelson Georges <ageorges@kss1.com>; Monterra Clubhouse Manager <clubhousemanager@monterracdd.com>; Dakota Harp <dakota@synturfintl.com>

Subject: Re: [EXTERNAL] Re: Benches for Basketball/Pickleball courts

Good morning,

Please see attached pictures of how your existing benches are installed

Regards

Colin Branson





Experience A Greener World

Colin Branson - Synthetic Turf International

O: 954.433.6608

C: 650.898.2177

www.stiofsouthflorida.com

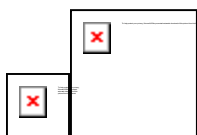

On Wed, Jun 17, 2026 at 8:51 PM Jason Weinrub <jason.weinrub@monterracdd.com> wrote:

Peter P or Keith, please let us know if the first option is feasible so we can move forward without any more delays.

Jason

Get [Outlook for iOS](#)

From: Colin Branson <colin@synturfintl.com>

Sent: Wednesday, 17 June 2026 19:47:26

To: Ladner, Elizabeth <lladner@inframark.com>

Cc: Pete Monzon <pete@jdsasphalt.com>; ppellerito@millerlegg.com <ppellerito@millerlegg.com>; kschriner@millerlegg.com <kschriner@millerlegg.com>; Jason Weinrub <jason.weinrub@monterracdd.com>; Adelson Georges <ageorges@kss1.com>; Monterra Clubhouse Manager <clubhousemanager@monterracdd.com>; Dakota Harp <dakota@synturfintl.com>

Subject: Re: [EXTERNAL] Re: Benches for Basketball/Pickleball courts

Hi everyone,

I have spoken with Keith and Jason regarding the bench installation. While the emails from February indicated that the benches should be moved to the opposite ends of the court, there was no clear confirmation on whether our team or yours would handle the final installation once the court was completed.

Currently, this is not in our scope of work; the plans specifically stated that the benches were to be removed and returned to the owner. Had we been asked to perform the installation initially, it would have required a change order and plan revisions submitted to the city, likely causing delays.

However, after discussing this with my team, we are happy to accommodate the request and secure the benches for you at no additional charge. Our proposed method is to drill into the asphalt, bolt them down, and apply a sealant to prevent water seepage. I suggest performing this work after the court installation is finished and all inspections have passed.

Alternatively, we could issue a change order to postpone the acrylic portion of the project, alter the plans, and submit them to the city to install concrete footers. Please note that this option would delay the project significantly due to the permitting process.

Please let me know how you would like to proceed and I will put together an RFI

Regards,
Colin Branson

Experience A Greener World

Colin Branson - Synthetic Turf International

O: 954.433.6608

C: 650.898.2177

www.stiofsouthflorida.com



On Wed, Jun 17, 2026 at 1:05 PM Ladner, Elizabeth <lladner@inframark.com> wrote:

Colin,

Please work with Peter and Keith to complete the reinstallation.

Lynne Ladner

District Manager

Monterra Community Development District

lladner@inframark.com

cell: 561-446-4821

All topics requested to be brought before the Monterra CDD Board of Supervisors must be submitted to the District Manager by 3 PM on the 3rd Friday of the month before the regularly scheduled board meeting. All supporting documentation must be included with the topic submission. Any topic or submission that is submitted after this deadline will be deferred to the next regular board meeting. Please contact me with any questions.

From: Colin Branson <colin@synturfintl.com>
Sent: Wednesday, June 17, 2026 11:37 AM
To: Ladner, Elizabeth <lladner@inframark.com>
Cc: Pete Monzon <pete@jdsasphalt.com>; ppellerito@millerlegg.com; kschriner@millerlegg.com; jason.weinrub@monterracdd.com; Adelson Georges <ageorges@kss1.com>; clubhouse manager <clubhousemanager@monterracdd.com>
Subject: [EXTERNAL] Re: Benches for Basketball/Pickleball courts

This message is from an external sender. DO NOT CLICK on links or attachments unless you recognize the sender and know the content is safe.

Dear Lynne,

We followed engineering plans provided by Miller Legg, which directed us to remove the existing benches and return them to the owner, we have placed the benches at the top of the staircase near the court entrance.

We can reinstall and secure them at the ends of the courts once the current installation is complete. Please let us know if you would like us to proceed with this.

Regards,
Colin Branson

Experience A Greener World

Colin Branson - Synthetic Turf International

O: 954.433.6608

C: 650.898.2177

www.stiofsouthflorida.com

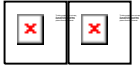

On Wed, Jun 17, 2026 at 10:53 AM Ladner, Elizabeth <lladner@inframark.com> wrote:

Good morning,

It has been brought to my attention that the issue with benches/seating for the new basketball and pickleball courts is in question. Attached is the email chain from February where the decision was made and a drawing provided for the reuse of the benches that had previously been located at the basketball courts. Please let me know why we are now being told that there are not any plans for seating at the courts. As we were reusing the benches that were owned by the CDD where were they stored? Please let me know ASAP where the disconnect on this issue occurred and how to ensure that it is resolved before the courts open. Thank you.

Lynne Ladner

District Manager

Monterra Community Development District

lladner@inframark.com

cell: 561-446-4821

All topics requested to be brought before the Monterra CDD Board of Supervisors must be submitted to the District Manager by 3 PM on the 3rd Friday of the month before the regularly scheduled board meeting. All supporting documentation must be included with the topic submission. Any topic or submission that is submitted after this deadline will be deferred to the next regular board meeting. Please contact me with any questions.

----- Forwarded message -----

From: "Ladner, Elizabeth" <lladner@inframark.com>

To: Peter Pellerito <PPellerito@millerlegg.com>, Keith Schriener <kschriener@millerlegg.com>, Colin Branson <colin@synturfintl.com>

Cc: Jessica Romer <jromer@millerlegg.com>, 06-00168 Monterra CDD <06-00168@millerlegg.com>

Bcc:

Date: Wed, 25 Feb 2026 15:29:28 +0000

Subject: RE: Monterra CDD Basketball/Pickleball Impr (CCC Permit)

Peter,

Thank you for checking. Let's proceed with placing the benches at either end of the project as was shown in the diagram yesterday.

Lynne Ladner

District Manager

Monterra Community Development District

lladner@inframark.com

cell: 561-446-4821

All topics requested to be brought before the Monterra CDD Board of Supervisors must be submitted to the District Manager by 3 PM on the 3rd Friday of the month before the regularly scheduled board meeting. All supporting documentation must be included with the topic submission. Any topic or submission that is submitted after this deadline will be deferred to the next regular board meeting. Please contact me with any questions.

From: Peter Pellerito <PPellerito@millerlegg.com>

Sent: Wednesday, February 25, 2026 8:53 AM

To: Ladner, Elizabeth <lladner@inframark.com>; Keith Schriener <kschriener@millerlegg.com>; Colin Branson <colin@synturfintl.com>

Cc: Jessica Romer <jromer@millerlegg.com>; 06-00168 Monterra CDD <06-00168@millerlegg.com>

Subject: RE: Monterra CDD Basketball/Pickleball Impr (CCC Permit)

Lynn

Benches located in these areas present a safety concern. A 5-foot setback is already below the preferred safety buffer, where a minimum of 10 feet is recommended. Introducing obstructions within this reduced buffer zone — including benches, spectators, and associated equipment — increases the risk of player collisions and injury.

Placement at the ends of the courts represents the safer and more appropriate option.

Please let me know if you have any questions or require additional information

Regards

Peter Pellerito, P.E.

Sr. Engineer

Miller-Legg

[13680 N.W. 5th Street](#), Suite 200

Sunrise, Florida 33325

d | (954) 628-3616 o | (954) 436-7000 c | (239) 410-2394

From: Ladner, Elizabeth <lladner@inframark.com>

Sent: Tuesday, February 24, 2026 4:22 PM

To: Keith Schriner <kschriner@millerlegg.com>; Peter Pellerito <PPellerito@millerlegg.com>; Colin Branson

<colin@synturfintl.com>

Cc: Jessica Romer <jromer@millerlegg.com>; 06-00168 Monterra CDD <06-00168@millerlegg.com>

Subject: RE: Monterra CDD Basketball/Pickleball Impr (CCC Permit)

Keith, Colin, and Peter,

I spoke with the board chair and he thought if it is possible to put the benches back to back on either side of the divider fence between the basketball court and the pickleball courts that would be his preference but if that is not possible without issues for the courts and their layout than we definitely want the benches and to install two benches on each end as shown in the figure below.

Lynne Ladner

District Manager

Monterra Community Development District

lladner@inframark.com

cell: 561-446-4821

All topics requested to be brought before the Monterra CDD Board of Supervisors must be submitted to the District Manager by 3 PM on the 3rd Friday of the month before the regularly scheduled board meeting. All supporting documentation must be included with the topic submission. Any topic or submission that is submitted after this deadline will be deferred to the next regular board meeting. Please contact me with any questions.

From: Keith Schriener <kschriner@millerlegg.com>

Sent: Tuesday, February 24, 2026 2:49 PM

To: Ladner, Elizabeth <lladner@inframark.com>; Peter Pellerito <PPellerito@millerlegg.com>; Colin Branson <colin@synturfintl.com>

Cc: Jessica Romer <jromer@millerlegg.com>; 06-00168 Monterra CDD <06-00168@millerlegg.com>

Subject: RE: Monterra CDD Basketball/Pickleball Impr (CCC Permit)

Good afternoon,

Sincerely,

Keith R. Schriener

Civil Engineer II



Improving Communities. Creating Environments.

[13680 NW 5th Street, Suite 200, Sunrise, FL 33325](#)

d | (954) 440-5039 o | (954) 436-7000 x5039



www.millerlegg.com

From: Ladner, Elizabeth <lladner@inframark.com>
Sent: Tuesday, February 24, 2026 12:41 PM
To: Peter Pellerito <PPellerito@millerlegg.com>; Keith Schriener <kschriner@millerlegg.com>; Colin Branson <colin@synturfintl.com>
Cc: Jessica Romer <jromer@millerlegg.com>; 06-00168 Monterra CDD <06-00168@millerlegg.com>
Subject: RE: Monterra CDD Basketball/Pickleball Impr (CCC Permit)

Keith and Peter,

Unless there are new benches included in the approved project, I believe the best solution would be to reuse the existing benches.

Lynne Ladner

District Manager

Monterra Community Development District

lladner@inframark.com

cell: 561-446-4821

All topics requested to be brought before the Monterra CDD Board of Supervisors must be submitted to the District Manager by 3 PM on the 3rd Friday of the month before the regularly scheduled board meeting. All supporting documentation must be included with the topic submission. Any topic or submission that is submitted after this deadline will be deferred to the next regular board meeting. Please contact me with any questions.

From: Peter Pellerito <PPellerito@millerlegg.com>
Sent: Tuesday, February 24, 2026 8:19 AM
To: Keith Schriener <kschriner@millerlegg.com>; Ladner, Elizabeth <lladner@inframark.com>; Colin Branson <colin@synturfintl.com>
Cc: Jessica Romer <jromer@millerlegg.com>; 06-00168 Monterra CDD <06-00168@millerlegg.com>
Subject: RE: Monterra CDD Basketball/Pickleball Impr (CCC Permit)

The DM will need to weigh in on the final placement; however, unless otherwise directed, please proceed with coordinating with the contractor to place it at the end as stated.

Peter Pellerito, P.E.

Sr. Engineer

Miller-Legg

[13680 N.W. 5th Street, Suite 200](#)

Sunrise, Florida 33325

d | (954) 628-3616 o | (954) 436-7000 c | (239) 410-2394

From: Keith Schriener <kschriner@millerlegg.com>

Sent: Thursday, February 5, 2026 4:37 PM

To: Ladner, Elizabeth <lladner@inframark.com>; Colin Branson <colin@synturfintl.com>

Cc: Peter Pellerito <PPellerito@millerlegg.com>; Jessica Romer <jromer@millerlegg.com>; 06-00168 Monterra CDD <06-00168@millerlegg.com>

Subject: RE: Monterra CDD Basketball/Pickleball Impr (CCC Permit)

Lynn/Peter,

One thing that came up at the pre-con was about the two existing benches. The plans currently call for them “to be removed and returned to owner.” Does the CDD want these re-installed inside the fenced in area or did you want to go with a different product? See below where I’d recommend they get placed and bolted inside the court if you want them reinstalled. If we spec’ a different product, we can do two at each end. Please provide your input.

10'

27.5'

PROP. 320-LF, 8'H BLK
VINYL COATED PERIMETER
CHAIN LINK FENCE (TYPE)

If we re-use the two existing on site benches, can place one OC at each end. If we wanted to spec' the other product, then I'd recommend two at each end spaced evenly along the fence

GRASS

10'

Other product – similar metal bleachers but a single bench unit.



CONCRETE FOOTING
By OTHERS

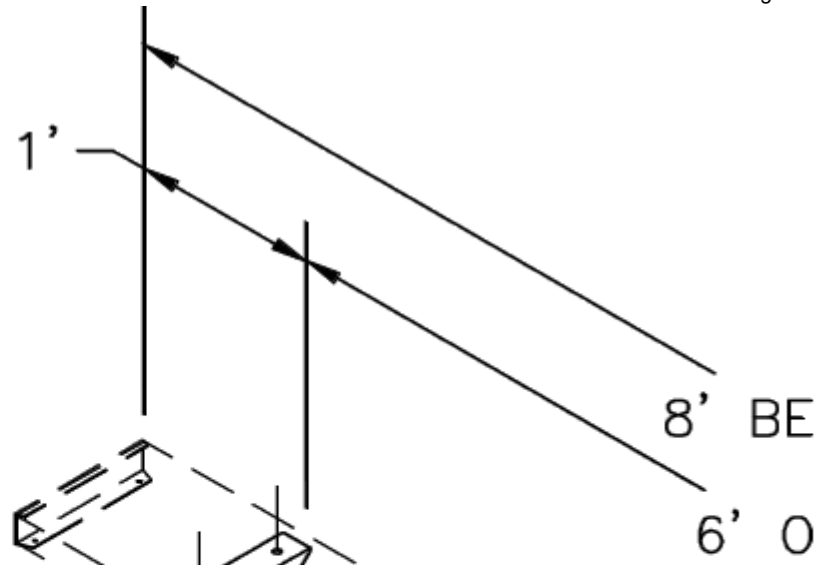

2x10 Seat Plank

ISOMETRIC VIEW OF BENCH ASSEMBLY

Note: Seat Plank Shown Dotted for Clarity

Kind regards,

Keith R. Schriener

Civil Engineer II



Improving Communities. Creating Environments.

[13680 NW 5th Street, Suite 200, Sunrise, FL 33325](#)

d | (954) 440-5039 o | (954) 436-7000 x5039



www.millerlegg.com

From: Ladner, Elizabeth <lladner@inframark.com>
Sent: Thursday, February 5, 2026 2:40 PM
To: Colin Branson <colin@synturfintl.com>; Keith Schriener <kschriener@millerlegg.com>
Cc: Peter Pellerito <PPellerito@millerlegg.com>; Jessica Romer <jromer@millerlegg.com>; 06-00168 Monterra CDD <06-00168@millerlegg.com>
Subject: RE: Monterra CDD Basketball/Pickleball Impr (CCC Permit)

Colin,

Please revise the Fencing line item to remove any references to batting cage. Thank you.

Court Surfacing

Court Resurfacing Scope of Work:

- Flood existing court for any ponding.
- Adding of Leveler/Binder to fill any areas.
- Two (2) Coats of Acrylic Resurfacer.
- Two (2) Coats of approved Laykold Standard Colors.

Includes markings for:

- One (1) Basketball Court.
- Two (2) Pickeball Courts
- two (2) portable Pickleball Nets

Basketball Goal Post

-Furnish and Install:

- Two (2) New Adjustable Basketball system(Poles , Backboard, Rims & Nets)

Court Fencing

Approx 540 LinFt of fencing 8' high to be installed around perimeter of basketball court **and batting cage**

Concrete

Additional concrete work to be done: 2 concrete walkways

Walkway 1 - 38' x 5' x4" and

Walkway 2 - 35' x 5' x4"

4 concrete slabs 4' x 7' for benches along the court.

Lynne Ladner

District Manager

Monterra Community Development District

lladner@inframark.com

cell: 561-446-4821

All topics requested to be brought before the Monterra CDD Board of Supervisors must be submitted to the District Manager by 3 PM on the 3rd Friday of the month before the regularly scheduled board meeting. All supporting documentation must be included with the topic submission. Any topic or submission that is submitted after this deadline will be deferred to the next regular board meeting. Please contact me with any questions.

From: Colin Branson <colin@synturfintl.com>

Sent: Thursday, February 5, 2026 2:23 PM

To: Keith Schriener <kschriner@millerlegg.com>

Cc: Ladner, Elizabeth <lladner@inframark.com>; Peter Pellerito <PPellerito@millerlegg.com>; Jessica Romer <jromer@millerlegg.com>; 06-00168 Monterra CDD <06-00168@millerlegg.com>

Subject: Re: Monterra CDD Basketball/Pickleball Impr (CCC Permit)

Hi Keith,

Please find the attached itemized quote for your review.

As discussed during our site visit with Jessica, the fencing price has increased due to rising material costs and the additional labor required for the interior court fencing.

Regarding the concrete work, the plans specify the removal and replacement of two walkways. We have confirmed the site measurements as 38' x 5' and 35' x 5', both at a 4" thickness. This scope also includes the removal of four existing 4' x 7' concrete slabs to accommodate the benches along the court.

Please let me know if you have any questions.

Best regards,

Colin Branson

Experience A Greener World

Colin Branson - Synthetic Turf International

O: 954.433.6608

C: 650.898.2177

www.stiofsouthflorida.com



On Thu, Feb 5, 2026 at 9:11 AM Keith Schriener <kschriner@millerlegg.com> wrote:

Good morning,

The increase was in the fencing total (+\$5,175) and the additional line item for concrete (\$4,565) for a total increase of \$9740 – see below snippets.

That being said, the scope for your fencing line item description is off. The plans call for approximately 320-LF, 8-ft high perimeter fencing and a total of 104-LF, 4-ft high interior fencing (no batting cage that I'm aware of). Seems like there could be a deduct considering you previously quoted 540-LF, 12-ft high fence. Please provide one line item for each fence height so we can compare pricing.

Please provide a quantity in your line item for the concrete. To answer one of your questions in the email thread. There's no concrete boarder around the new court. The fence will be placed at the edge of pavement and the grade will stay flat for 1-ft offset before grading down to existing grade at 4:1.

We can get on a call sometime today if needs be.

Original Quote

Court Fencing

Approx 540 LinFt of fencing 12' high to be installed around perimeter of basketball court and batting cage

Thank you for the opportunity to work with you! Please let us know if you have any questions or need anything else! - Thank you for considering Synthetic Turf Intl Group!

SL
TA

New Quote

Court Fencing

Approx 540 LinFt of fencing 12' high to be installed around perimeter of basketball court and batting cage

Concrete

Additional concrete work to be done to the concrete walkways and the 4 concrete benches

Thank you for the opportunity to work with you! Please let us know if you have

SU

Kind regards,

Keith R. Schriener

Civil Engineer II



Improving Communities. Creating Environments.

[13680 NW 5th Street, Suite 200, Sunrise, FL 33325](#)

d | (954) 440-5039 o | (954) 436-7000 x5039



www.millerlegg.com

From: Ladner, Elizabeth <ladner@inframark.com>

Sent: Thursday, February 5, 2026 8:20 AM

To: Colin Branson <colin@synturfintl.com>; Peter Pellerito <PPellerito@millerlegg.com>
Cc: Keith Schriener <kschriner@millerlegg.com>; 06-00168 Monterra CDD <06-00168@millerlegg.com>
Subject: RE: Monterra CDD Basketball/Pickleball Impr (CCC Permit)

Colin,

Can you please provide me with documentation of which lines in the new invoice have been changed and by how much? Thank you

Lynne Ladner

District Manager

Monterra Community Development District

lladner@inframark.com

cell: 561-446-4821

All topics requested to be brought before the Monterra CDD Board of Supervisors must be submitted to the District Manager by 3 PM on the 3rd Friday of the month before the regularly scheduled board meeting. All supporting documentation must be included with the topic submission. Any topic or submission that is submitted after this deadline will be deferred to the next regular board meeting. Please contact me with any questions.

From: Colin Branson <colin@synturfintl.com>
Sent: Wednesday, February 4, 2026 7:53 PM
To: Peter Pellerito <PPellerito@millerlegg.com>
Cc: Ladner, Elizabeth <lladner@inframark.com>; Keith Schriener <kschriner@millerlegg.com>; 06-00168 Monterra CDD <06-00168@millerlegg.com>
Subject: Re: Monterra CDD Basketball/Pickleball Impr (CCC Permit)

Good Evening,

Please find attached the revised estimate for the additional fence and concrete work required for the project.

The initial deposit received was \$38,185. To begin the project, we require a total deposit equal to 50% of the final price. Therefore, an additional deposit of \$47,585 is required to proceed.

Please advise how you would like to proceed. I can send you the invoice and we can work on getting this on the schedule

Best regards,

Colin Branson

Experience A Greener World

Colin Branson - Synthetic Turf International

O: 954.433.6608

C: 650.898.2177

www.stiofsouthflorida.com



On Wed, Feb 4, 2026 at 3:41 PM Peter Pellerito <PPellerito@millerlegg.com> wrote:

Colin

No walkway rails are required. Based on a review of the site photographs, a portion of the existing sidewalk can be salvaged. Only an approximate 12-foot section of sidewalk removal and replacement is necessary to achieve the required 1:12 slope resulting from the 1-ft vertical raised pickleball court elevation. Earthen fill will be placed on both sides of the sidewalk ramp to eliminate any grade differential and avoid drop-off conditions.

Please let me know if you have any questions or require additional information

Peter Pellerito, P.E.

Sr. Engineer

Miller-Legg

[13680 N.W. 5th Street, Suite 200](#)

Sunrise, Florida 33325

d | (954) 628-3616 o | (954) 436-7000 c | (239) 410-2394

From: Colin Branson <colin@synturfintl.com>

Sent: Wednesday, February 4, 2026 2:25 PM

To: Peter Pellerito <PPellerito@millerlegg.com>

Cc: Ladner, Elizabeth <lladner@inframark.com>; Keith Schriener <kschriener@millerlegg.com>; pete jdsasphalt.com <pete@jdsasphalt.com>; 06-00168 Monterra CDD <06-00168@millerlegg.com>

Subject: Re: Monterra CDD Basketball/Pickleball Impr (CCC Permit)

Peter,

Please can you confirm on the plans if we are doing walkway rails on both of the pathways we are building. They are not on the plans but we don't want to have issues after install.

Please confirm so I can finalize pricing

Regards

Colin Branson

Experience A Greener World

Colin Branson - Synthetic Turf International

O: 954.433.6608

C: 650.898.2177

www.stiofsouthflorida.com



On Tue, Feb 3, 2026 at 4:34 PM Colin Branson <colin@synturfintl.com> wrote:

Please can you resend the plans.

I can't find it in the email thread

Regards

Colin Branson

Experience A Greener World

Colin Branson - Synthetic Turf International

O: 954.433.6608

C: 650.898.2177

www.stiofsouthflorida.com



On Tue, Feb 3, 2026 at 10:45 AM Colin Branson <colin@synturfintl.com> wrote:

We can start within a week or two once we confirm the final scope of work.

After looking at the plans with Jessica there are a couple things we need to adjust. I'm working on pricing for the concrete and the additional work with the fence. It also looks like we will need to do a concrete footer around the entire perimeter of the court.

Can you confirm if you are wanting rails on both walk ways entering to court ?

I will hopefully have the final price for you by end of day today or tomorrow morning.

Regards

Colin Branson

Experience A Greener World

Item #

**Monterra Community Development District
Board of Supervisors Agenda Memorandum
Office of the District Manager**

Meeting Date: July 1, 2026
Subject: Consideration of rental for indoor and outdoor mats for clubhouse to reduce wet floor risk

The Clubhouse manager collected proposals from Cintas and Unifirst for delivery, placement and cleaning of 1 4x6 outdoor mat and 1 3 x 10 indoor mat to place near the doors to the pool deck to reduce the risk of wet floors in the clubhouse during high usage times in the clubhouse pool.

Cintas' proposal cost is \$55 per week totaling \$2,860 per year.
Unifirst's proposal cost is \$68.25 per week totaling \$3,549 per year.



Lynne Ladner



HARD-WORKING STYLE & COMFORT

READY™



FLOOR ZONE SERVICES

MOP TOOLS & SERVICES

- Products capture and remove soil and moisture from floors
- Cintas professionally launders and replaces mop heads each week



SIGNET® CLEANING CHEMICAL SERVICE

- Wall-mounted system safely dispenses proper amount and type of cleaning chemical needed
- Convenience and organization promotes safe handling and measuring of cleaning chemicals
- Cintas monitors, refills and maintains the dispenser weekly



MAT SERVICES: HIGH PERFORMANCE SERIES™

CINTAS ACTIVE SCRAPER™

Captures **3X more dirt and debris** than a standard scraper mat

CINTAS XTRACTION™

10X the surface area of a standard mat to capture more dirt and water

CHOICES:

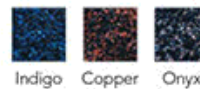

CINTAS TRAFFIC™

Highest traction rating ever recorded by NFSI for transitional coefficient of friction
National Floor Safety Institute, February 2016

CINTAS PHOTO™

50% more resolution enhances vibrancy and clarity

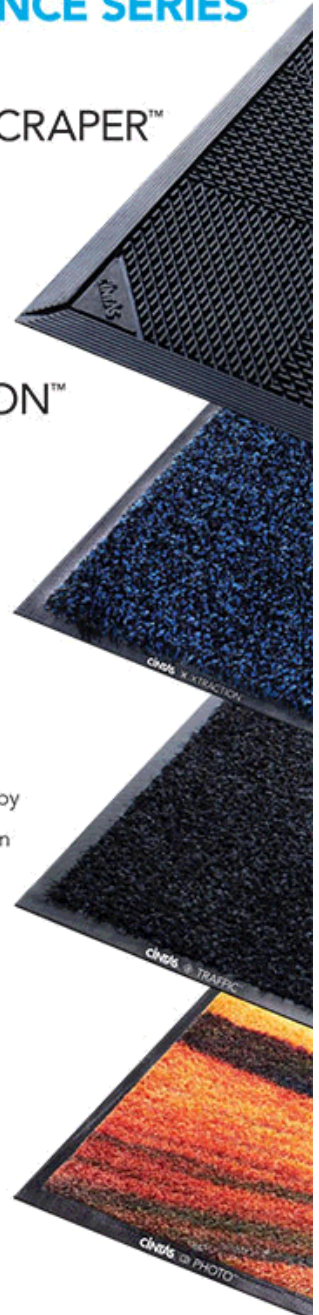

RESTROOM ZONE SERVICES

RESTROOM MATS / SCREENS

- Regularly scheduled Cintas service removes dirty items and replaces them with fresh, new ones



Commode Mat



Urinal Mat



Urinal Screen

CINTAS ULTRACLEAN® RESTROOM CLEANING

- Restroom deep cleaning service translates to easier daily maintenance that boosts employee morale
- Surfaces are sanitized and high-pressure cleaning removes soil and bacteria to provide a clean not attainable with regular cleaning tools

DIY METHOD



CINTAS

DIY METHOD



CINTAS

RESTROOM DISPENSERS: SIGNATURE SERIES™

- Stylish, sophisticated line of designer restroom dispensers
- Non-textured surface resists most fingerprints, makes cleaning easier and minimizes germs
- Cintas monitors, refills and maintains the dispensers weekly

CHOICES:

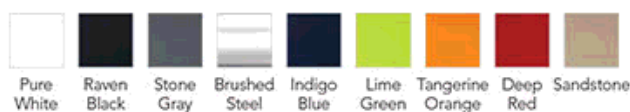

Hand Soap / Hand Sanitizer



Automatic Hand Soap / Hand Sanitizer



Toilet Paper



Paper Towel



Automatic Paper Towel



Air Freshener



Air Freshener Advanced



Toilet & Urinal Sanitizer



Toilet Seat Cleaner



Trash Can



Proposal Date: 06/12/2026

Expiration Date: 07/12/2026

Customer Name Monterra Community Development District		Prepared For Monterra Community Development District	
Delivery Address 8451 Monterra Blvd		Delivery Address 2 :	
City : Hollywood	State / Province : FL	Zip / Postal Code : 33024	Phone : 561-446-4821

Facility Services

Non-Garment / Service Group 1

Non-Garments / Services	Frequency	Inventory	Unit Price	Price
 X10202 3X10 XTRAC MAT ONYX	Weekly	4	\$ 10.000	\$ 40.000
Auto LR: No Buy Back: No				
 X10192 4X6 XTRAC MAT ONYX	Weekly	1	\$ 8.000	\$ 8.000
Auto LR: No Buy Back: No				
 X8072 SIG SANT SVC	Weekly	1	\$ 2.000	\$ 2.000
Auto LR: No Buy Back: No				
Weekly Total :			\$	50.00

Other Charge

Charge Description	Price Per Week
Service Charge	\$ 5.00

Total

Charge Description	Sale Price
Weekly Delivery Total	\$ 55.00

#

Sales Partner
 JAMES.WEIRICK@CINTAS.COM

UR v1

Ladner, Elizabeth

From: Monterra Clubhouse Manager <clubhousemanager@monterracdd.com>
Sent: Wednesday, June 24, 2026 11:14 AM
To: Ladner, Elizabeth
Cc: Camille, Berloune
Subject: [EXTERNAL] Fw: Monterra CDD Mat Rental Proposal
Attachments: Monterra proposal.pdf

This message is from an external sender. DO NOT CLICK on links or attachments unless you recognize the sender and know the content is safe.

Hello,

Here are 2 proposals to rent the mats for the weekends for the CDD.
One is from Cintas and the other from UniFirst.

Cintas

Check the attachment 'monterra proposal'

Unifirst (they sent me via email what it will cost for the weekly rentals. - Look below in this email)

"These are the appropriate mats for what the board is looking to use them for. Please let me know if you or the board have any questions. Thank you!

- 4x6 Outdoor Scraper Mats 5389: \$4 each; \$8 weekly
- 3x10 Indoor Walk-Off Mats 76GH: \$8 each; \$48 weekly

We have a delivery fee of \$12.25 which also covers the washing so the weekly total before tax would be \$68.25"

That's all!
Richard A.

From: Sophia Labow <Sophia_Labow@unifirst.com>
Sent: Tuesday, June 16, 2026 11:05 AM
To: Monterra Clubhouse Manager <clubhousemanager@monterracdd.com>
Subject: Mat Rental Proposal

Good morning Richard,

I have attached the digital catalog for you to show to the board. I will include the item numbers in the proposal so they can match the pricing to the items in the catalog. I will be quoting the two outdoor

scraper mats and the 6 indoor mats we discussed. These are the appropriate mats for what the board is looking to use them for. Please let me know if you or the board have any questions. Thank you!

- 4x6 Outdoor Scraper Mats 5389: \$4 each; \$8 weekly
- 3x10 Indoor Walk-Off Mats 76GH: \$8 each; \$48 weekly

We have a delivery fee of \$12.25 which also covers the washing so the weekly total before tax would be \$68.25

Best regards,

Sophia Labow

Sales Representative
UniFirst Corporation
500 S.W. 13th Terrace
Pompano Beach, FL 33069
Cell: 561-445-4352
Sophia_Labow@UniFirst.com



MONTERRA COMMUNITY DEVELOPMENT DISTRICT

District Manager Report – June 2026

- ✓ Scheduled and Rescheduled review with City of Cooper City for Traffic Calming Study
- ✓ Met with vendors onsite as part of their weekly meeting with onsite staff, did a drive around with CNI, Juniper, and Southern Plant & Pest identifying outstanding projects that have been requested, areas where the vendors need to complete work to contract or provide proposals for out of scope work that needs to be completed
- ✓ Provided board member copies of matrix for scoring Engineering RFQ submissions and contacted proposers about the brief presentation opportunity at the July meeting
- ✓ Met with Supervisor Kooiman to begin revising the Landscaping RFP for rebid
- ✓ Election qualifying closed at noon on June 12th. Seat #2 has two qualified candidates – Syed Hashem and Adam Zee. Seat #4 has one unopposed candidate Jason B. Weinrub. Seat #5 has one unopposed candidate Avi Ciechanowiecki.

CLEAR PARTNERSHIPS



COLLABORATION



LEADERSHIP



EXCELLENCE

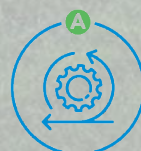

ACCOUNTABILITY



RESPECT

Project	Status	Contractor	Start Date	Notes
Pickleball	Permit issued - construction scheduled	SynTurf International	2/18/2026	<p>2/18 on site to fence off the construction area along with the surveyor. 2/19 begin the fence removal - 2-3 days. 2/23 begin work raising the existing court 2/20 Fence removal has started and the project is currently proceeding as scheduled. 2/20 work raising the surface level will begin Mar. 2, tentative project completion April 3 3/6 Construction continues preparing to raise the base 3/13 Base has been laid, waiting on cure period before next step of the surfacing 3/20 approved paint color layout for the new courts 4/3 Had a meeting with the contractor and engineer. There are concerns at this point about the contractor work quality on this project and there seems to be a potential delay as there have been challenges getting the necessary signed engineering drawings for the basketball hoop structures.4/10 Engineers report on the project was reviewed by the board we have requested that the contractor stop work until construction deviations can be addressed. 4/17 work continues to be stopped awaiting additional information from the engineer and contractor. This item will be discussed at the special meeting on the 28th. 5/1 BoS appointed Supv. Popowitz to work with contractor and engineer regarding geotechnical report and changes to construction plans 5/20 Contractor has been sent small project agreement, and the conditions for the district to notice to continue to be granted. 6/12 Final revised small project agreement executed and contractor authorized to return to work on 6/5, anticipated completion 6/25</p>
Road Paving	Permit issued - construction scheduled	All County Paving	3/2/2026	<p>Week of 2/16 - walk through with engineer for marking pavement, Week of 2/23 contractor to video project area, 3/2/26 - Construction start 2/20 Contractor has completed walk-thru. Due to duration of the project the contractor has been granted permission to utilize restroom facilities in the Pine Island Guardhouse rather than having a Port-a-Potty on site for approximately 4 months which would be unsightly and an attractive nuisance when contractor staff not on site. 2/27 contractor staging materials week of Feb 27th. mill in area 1 anticipated March 2nd 3/6 Contractor completing curb and gutter replacement 3/13 Curb and gutter replacement in process, some delays due to rain 3/20 Recieved cost to add additional 45' of C&G for recommended replacement, hoping to get cost quote for location that on NW 40th before I approve the change orders. 4/3 The district engineer contacted me on Friday to let me know that the paving contractor has brought forward the impact of the increase in the cost of asphalt and fuel from the conflict overseas. They will be attending the meeting on 4/8 to discuss the impact on the current contract. 4/10 Paving continues, there have been several days this week where the contractor has not been able to work due to weather which has delayed the project. Mill and Repaving begins on 4/13 in the Solano area. 4/17 work continues with Solano and Capistrano having been completed or in process this week. Paving to begin on Monterra Blvd next week. 5/1 paving completed. Working on striping and waiting on asphalt to cure before laying thermoplastic 5/20 Contractor is scheduled for a walk-thru with Engineer the week of 5/26 to identify punchlist items to close out project 6/12 contractor working to complete punchlist items 6/19 Punchlist items still being resolved</p>

Project	Status	Contractor	Start Date	Notes
Playground	Correction to 2/10/26	A & A Playgound		<p>2/10/26 and the submittals were sent back to the contractor on 12/29/25 with ten (10) comments. There has been no additional activity on the permit since, no additional submittals or revisions. 2/20 contractor has submitted revisions as requested by city. I will follow up during the week of 2/27 with the city to determine if the permit needs additional revisions or if the permit is ready for issuance. I will update on 2/27 2/27 I have asked the playground contractor to attend the March 4th meeting of the board 3/6 Contractor did not attend board meeting. Left message with Cooper City CD department requesting permit status 3/13 City informed DM that following review the permit application has been sent back to the contractor with additional comments on 3/8. DM has requested a timeline from the contractor for submitting responses to the new comments. 3/20 no new information from vendor 4/3 Vendor has informed us that the City has placed a new requirement on the project that a walkway is required now. I will be reaching out to the City to get a better understanding of this new requirement for the permit and why it is just being required and will let you know at the meeting what I find out. 4/10 no additional information from the contractor regarding the pathway to the equipment DM will follow up. 4/17 DM reached out to the City and was informed that the pathway was originally brought to the contractor's attention when comments were sent from the city in Dec. of 25, an accessible pathway connecting the sidewalk outside of the fence to the ground level area of the playground will need to be constructed. The question is whether the City will allow the permit to be approved with the pending requirement of the pathway. DM has requested that option but has not been informed as of yet whether it will be allowed. Contractor working with City on additional permitting issues. ML provided a quote to complete the survey, design and permitting assistance for construction of required accessible pathway 5/20 Engineer is working on site plan, Topo survey and sidewalk design and construction drawings. Per CC, there are still some outstanding items with the contractor before the permit for work will be issued. 6/12 Contractor has submitted updated/ revised site plan and other required documents this week hopefully permit will be issued ASAP. 6/19 City has requested additional information from last</p>
FPL Lighting	Zoning Approved, agreement signed FPL responsible for obtaining permit	FPL	TBD	<p>agreement and associated information approved Feb. 2025. FPL will be sending an invoice for deposit that may need board approval. FPL is responsible for obtaining permitting from Cooper City. 2/20 Awaiting additional information from FPL as they begin the permitting process with the city. 2/27 nothing new 3/6 awaiting information from FPL 3/13 spoke with FPL rep. should receive deposit invoice in next week to ten days 3/20 Recieved the deposit invoice from FPL on 3/19 have submitted to A/P for check issuance to submit payment to FPL 4/3 No update at this time. 4/10 Nothing new at this time. 4/17 no change 5/20 No change, will follow up with FPL 6/12 FPL reached out, they are working on the design for this project. Requested new point of contact to speak with regarding the tree replacements that were promised as part of the restoration following the transmission line project. They are identifying who that will be as</p>

Project	Status	Contractor	Start Date	Notes
Pine Island Median	ITB drafted	TBD	TBD	<p>Once approval is on agenda for BCC for the City/County District agreement project will be put out to bid. 2/20 The Broward County attorney informed District Counsel that the previously signed Tri-party agreement had language that they were "uncomfortable" with and have drafted a new agreement which is being reviewed by their staff. Once the agreement is ready from the BC Attorney's office it will be sent to the city and district for review. If all parties accept the new agreement it will be presented to the board for approval. Hopefully that approval will happen simultaneously with the city and county's approval and we can issue the ITB to the public. 2/27 No new information at this time 3/6 waiting for County to send agreement for review 3/13 A revised amendment to the agreement between the city and the CDD was provided by district counsel for the DM and DE to review and make comments. Comments have been provided, the DE has provided the plans that have been updated and approved by the city and DC will be sending the county's approval letter and plans to the county and district approval. 3/20 DC sent the edits to the first amendment and the County plans approval to the County Attorney and City Attorney on 3/12/26. 4/3 the revised amendment/agreement between the county, city and district has been provided. I will add this item to the 4/8 meeting agenda for ratification of the board chairman's execution of the document. 4/10 Waiting on the City and County to complete their portion of the signature page for the amendment 4/17 not change waiting on authorization to issue ITB 5/1 waiting on final execution of agreement before publishing the ITB 5/20 this did not get placed on the June BoC meeting for BC, requesting it be walked on otherwise will not be considered until Aug at the earliest. 6/12 BCC approved agreement this week. Notice for the ITB will be published on 6/14 with pre-bid meeting 6/26 and proposals due 7/21 6/19 No change</p>
Traffic Calming	in process	TBD	TBD	<p>Board approved request to Cooper City to complete required traffic study. Awaiting Cooper City to complete 2/20 have been informed by the City that they require a formal resolution not just board approval. This will be on the March agenda, however we are waiting for the city to provide the required Indemnification and Hold Harmless agreement that must accompany the resolution. 2/27 waiting for hold harmless from city engineer 3/6 waiting for documents from City Engineer 3/13 Check request has been submitted to Inframark, Application and Fee will be submitted to Cooper City once it is received. The first study/application applies to Tarama from Monterra Blvd to Sheridan. Per city CIP Manager John Quintero 3/2/26 a petition and hold harmless agreement are not required for permit submission - this is a variance of the application checklist that was provided to the district. 3/20 Application and fee check submitted to Cooper City, awaiting traffic study 4/3 no update at this time 4/10 no new update 4/17 not update will follow up with City engineer for a date for the study 5/1 exchanging messages with city staff for scheduling of study 6/12 Cooper City engineering team will be onsite 6/17 to meet with security as first step of the study 6/19 Onsite visit to be rescheduled due to City staff dealing with emergency issue</p>

Project	Status	Contractor	Start Date	Notes
Landscaping	Drafting RFP for board approval			Draft will be available for approval at the March meeting 2/27 will be sending out final draft to add to the agenda for board approval 3/6 Sent to paper for publication on 3/10 3/13 have been contacted by 2 companies so far, arranged for one required district tour and expect more to come. 3/20 there have been tours this week, there is 2 weeks remaining until the 4/7 submittal deadline and hopefully we will get a few more tours before that. 4/3 There have been seven (7) companies tour the district in preparation for submission of a proposal to the district. 4/10 Bids were opened on 4/7 five proposals were received. DM will do reference checks and provide information to the board for a decision at the May meeting, 4/17 electronic copies of the proposals were sent to the board this week completing reference checks. 5/1 developing proposal scoring matrix for board to use at 5/6 meeting 5/20 directed to work with Supv. Kooiman to redraft the RFP after all bids were rejected.
Engineering RFQ	Drafting RFQ for board approval			Draft will be available for approval at the March meeting 2/27 will be sending out final draft to add to the agenda for board approval 3/6 Sent to paper for publication on 3/10 3/20 I have responded to questions from a couple different engineering firms this week. There is 2 weeks until the submittal deadline of 4/7 4/3 no update at this time 4/10 Submittals for Engineering Services were opened on 4/7, there are three proposals, copies were provided to the board members to review. DM will do reference checks and the board will make a decision at the May meeting 5/1 developing decision matrix for board meeting 5/6 5/20 Board deferred decision to June Meeting 6/12 deferred to July 1 meeting - board will be requesting a 10 min presentation from the submitting companies before making final decision
Tennis Court	Replace permanent net structure			3/6 Due to water issues the net has been replaced with a temporary net structure. District Engineer has recommended raising the surface to eliminate water issues, resurfacing and placing new net posts. Quote received from SyntheticTurf to complete the project in the amount of \$91,689 will present to board at April meeting 3/13 Nothing new 3/20 nothing to report 4/3 a proposal by the contractor for the pickleball courts has been provided for review by the board at their 4/8 board meeting 4/10 Board decided not to take action on the submitted proposal, will budget for the project in FY 27 6/12 Tentatively budgeted for FY 27
Pillar Cap Replacement				3/6 Caps are in storage at Clubhouse, Maint. Staff needs to install them along the fence line in the district. They are aware of this project and it was entered into the KW work order system Dec 19, 2025 3/13 staff are being provided photos from around the district to provide a starting place for the pillar cap replacements. 3/20 project being entered into work order system 4/3 no update at this time, maintenance has not yet begun the replacement project. 4/10 Project has not been started yet. 4/17 no progress at this time. 5/1 Project has been turned over to Kent Svs Maintenance for completion 5/20 Project underway, should be completed by the end of May, 6/12 Maintenance has completed this project

Project	Status	Contractor	Start Date	Notes
FPL Light Pole Relocation	Ticket opened with FPL	FPL		3/13 BSO issued a Fire Code compliance violation notice to the district on 3/9/26. A street light pole #86974071902 at 3899 NW 82nd Dr is too close to the fire hydrant in violation of Fire Code. The issue has been submitted to FPL, they have asked for a location where the pole is to be relocated. The DM will review and discuss with the district engineer after the DM visits the site on 3/13 and we will provide the information to FPL. FPL has stated that it will take more 30 days to complete the relocation and the DM has provided this information to the inspector that issued the notice. Inspectors auto-reply informed that they will not return to the office until 3/24 and the notice has a re-inspection date of 4/7/26. DM will follow up after the inspectors return to office. 3/20 still waiting on inspector to return. 4/3 Heard back from the fire inspector, they will waive the 4/9 deadline while we are working to bring this into compliance. 4/10 Have not heard anything new from FPL on the schedule or plans for this relocation 4/17 no change
Mattamy Agreements	working to identify responsible party	Mattamy Palm Beach LLC		4/10 DM was requested by the board to look into whether the agreed upon contributions were made to the district. As of now, neither the initial deposits nor the Performance Bond funds were received. We are working to identify the relevant party to notify that payment is required as the original contact is no longer valid. 4/17 no additional information at this time.
Estada Fence replacement		Monterra Staff		6/12 Working to collect response form individuals on how to remove and replace existing exterior fence for Estada development. Project must address multiple challenges that prevented previous attempt to solicit proposals including: limit space for ingress, egress and removal/construction due to mature screening landscaping. Challenges with mature landscaping root structures that have become entangled with landscaping materials on private property underneath and in some cases through the fence. 6/19 currently requesting replacement options from fencing companies for review by board
Electric or Solar power for Estada Aerators				6/12 Estada development requested and the board approved the purchase of commercial pond aerators for Lakes 1-4 of the development, however the request and subsequent attempt to install identified that there is not currently power available within the CDD maintenance area to connect the aerators. Currently exploring if there is an option to purchase a solar power cell that can be connected to each aerator to power the equipment without the need to construct line extension and power service for each lake 6/19 collecting cost estimates

Invoice/Proposal No.	Supplier	Invoice/Proposal Date	Property	Invoice Amount
Feb Comcast Mobile	Comcast/Infinity		Monterra CDD	
SPN105259.0	Hoover	6/16/2026	Monterra CDD	\$2,548.96
Dog Park, Gates 13 & 12 Repairs	ASAP Gate Plus	6/18/2026	Monterra CDD	\$1,733.00
3318 - Repair equipment	All American Fitness	6/22/2026	Monterra CDD	\$750.86
Quo-10289-H8R6C8	Matrix Equipment	6/4/2026	Monterra CDD	\$3,921.59

Lynne Ladner, District Manager

Lynne Ladner, District Manager

Item #

**Monterra Community Development District
Board of Supervisors Agenda Memorandum
Office of the District Manager**

Meeting Date: July 1, 2026
**Subject: Consideration of revisions to General Rules and
Procedures and set date for public hearing**

The board had a work session to discuss changes to the General Rules and Procedures for the District. The proposed revisions are included and the proposed public hearing date for August 12th.



Lynne Ladner

UPON APPROVAL BY THE MONTERRA COMMUNITY DEVELOPMENT DISTRICT BOARD OF SUPERVISORS, THESE RULES AND POLICIES REGARDING USE OF DISTRICT'S CLUBHOUSE FACILITIES SHALL BE EFFECTIVE. ALL PRIOR RULES OR POLICIES PREVIOUSLY IN PLACE REGARDING THE CLUBHOUSE FACILITIES ARE HEREBY NULL AND VOID AND REPLACED WITH THESE RULES AND POLICIES REGARDING THE USE OF THE DISTRICT'S CLUBHOUSE FACILITIES.

A. USER FEE STRUCTURE

- (1) Annual user fees for an individual not owning property within the District, or an owner that leases his or her home to a lessee within the District, or who owns property within the Estada and Apartments 2F sections (also known collectively as "Members") shall be approved by resolution of the District and upon adoption shall be made a part of these Rules. An individual owning property within the District (other than property within Estada and Apartments 2F sections) whose property has not been leased to another individual shall be defined as an "Owner".
- (2) Two (2) Monterra ID/FOB Cards will be issued to Owner and non-resident fee ~~payers~~-paying member. There is a \$15.00 charge to replace lost cards. Replacement cards may be obtained through the Club Manager.
- (3) The person making a fee payment where a check is returned due to insufficient funds will be assessed a \$25.00 Returned Check/Insufficient Funds fee.
- (4) All guests must be accompanied by a Patron (as defined below) at all times. Patrons are limited to a maximum of four (4) guests, per ~~household~~Member, at a time. ~~Two (2) Four (4) adult guests per household~~Member are permitted at any one time. Children under the age of eighteen (18) are not included in the above limitation of number of guests. cat no charge; however, Patrons may purchase no more than an additional two (2) guest passes at \$15.00 each to increase the maximum number of guests to four (4) per household Member at any one time. Patrons must be present in order for guests to use the facility. However, guests are not permitted in the Fitness Center.
- (5) Patrons (as defined below), at the time of application for a facility access card or at anytime thereafter may be subjected to a criminal background or sexual offender/sexual predator check ordered or performed by the Club Manager or his or her designee.

B. GENERAL PROVISIONS

- (1) ~~Owners of Property within the District (excluding Estada and the Apartments 2F section)~~ and non-resident fee payers ("Patrons") must present their access cards and register upon entering the Club at Monterra club facilities ("Clubhouse") or when using District property.
- (2) Children under sixteen (16) years of age must be accompanied by a parent or authorized person eighteen (18) years or older.
- (3) The Clubhouse's hours of operation will be established and published by the District, and may be changed from time to time.
- (4) Alcoholic beverages shall not be served or sold, nor permitted to be consumed on the Clubhouse's premises, except at pre-approved special events. Approval may only be granted by the District's Board of Supervisors (present request to Club Manager in at least 48 hours in advance of the meeting) and will be contingent upon providing proof of event insurance with the Monterra CDD named as an additional insured.

- (5) Dogs or other pets (with the exception of service animals, such as “Seeing Eye Dogs”) are not permitted at the Clubhouse facilities, Pool deck, Tennis Courts, Basketball Courts, or Tot Lots. Where dogs are permitted on the grounds, they must be leashed at all times.
- (6) Vehicles must be parked in designated areas. Vehicles may not be parked on grass lawns, or in any way which blocks the normal flow of traffic.
- (7) Fireworks of any kind are not permitted anywhere on the facilities or adjacent areas.
- (8) The Board of Supervisors reserves the right to amend or modify these policies when necessary and will notify the Patrons of any changes.
- (9) The Board of Supervisors and personnel of the Clubhouse have full authority to enforce these rules and regulations.
- (10) Monterra/Clubhouse ID/FOB Cards will be issued to Patrons at the time they become entitled to use the facilities. All Patrons must use their card for entrance to the Clubhouse. All lost or stolen ID/FOB cards should be reported immediately to the Club Manager or Staff.
- (11) Smoking, including, but not limited to electronic cigarettes and vaping, is not permitted anywhere in the Clubhouse, Swimming Pool, Splash Pad, Tot Lots, Fitness Center, Tennis Courts, Pickleball Courts, Basketball Courts and Dog Parks.
- (12) Guests must be registered ~~and~~ or accompanied by a Patron before entering the Clubhouse or using any Clubhouse facilities. All residents must register with guests via email or in person and must sign in with the guest present.
- (13) Disregard for any Clubhouse rules or policies may result in expulsion from the facility and/or loss of Clubhouse facility privileges.
- (14) Glass and other breakable items are not permitted at the Clubhouse.
- (15) Patrons and their guests shall treat any staff members and other Patrons with courtesy and respect.

C. LOSS OR DESTRUCTION OF PROPERTY/INSTANCES OF PERSONAL INJURY

- (1) Each Patron and each guest as a condition of invitation to the premises of the Clubhouse assume sole responsibility for his or her property. The District and its contractors shall not be responsible for the loss of damage to any private property used or stored on the premises of the Clubhouse, whether in lockers or elsewhere.
- (2) No person shall remove from the room in which it is placed or from the Clubhouse's premises any property or furniture belonging to the District or its contractors without proper authorization. Clubhouse Patrons shall be liable for any property damage and/or personal injury at the Clubhouse, or at any activity or function operated, organized, arranged or sponsored by the District or its contractors, caused by the patron, any guests or any family members. The District reserves the right to pursue any and all legal and equitable measures necessary to remedy any losses due to property damage or personal injury.
- (3) Any Patron, guest or other person who, in any manner, makes use of or accepts the use of any apparatus, appliance, facility, privilege or service whatsoever owned, leased or operated by the District or its contractors, or who engages in any contest game, function, exercise, competition or other activity operated, organized, arranged or sponsored by the club, either on or off the Clubhouse's premises, shall do so at his or her own risk, and shall hold the Clubhouse, the District, the Board of Supervisors, District employees, District representatives, District contractors, and District agents harmless for any and all loss, cost, claim, injury damage or liability sustained or

incurred by him or her, resulting therefrom and/or from any act of omission of the, the District, or their respective operators, Supervisors, employees, representatives, contractors, or agents. Any Patron shall have, owe, and perform the same obligation to the Clubhouse or District and their respective operators, Supervisors, employees, representative, contractors, and agents hereunder in respect to any loss, cost, claim, injury, damage or liability sustained or incurred by any guest or family member of such Patron.

- (4) Should any party bound by these District Policies bring suit against the District or its affiliates, Clubhouse operator, officers, employees, representatives, contractors or agents in connection with any event operated, organized, arranged or sponsored by the District or any other claim or matter in connection with any event operated, organized, arranged or sponsored by the District, and fail to obtain judgment therein against the District or its Clubhouse operator, officers, employee, representative, contractor or agent, said party shall be liable to the District for all costs and expenses incurred by it in the defense of such suit (including court costs and attorney's fees through all appellate proceedings).

D. GENERAL SWIMMING POOL/SPLASH PAD RULES

- (1) At any given time, up to ~~two (2)~~ four (4) guests per household; may accompany a Patron at the swimming pool or splash pad; ~~however, Patrons may purchase additional guest passes as provided for in Rule A (3) above. Patrons and their guests are limited to a maximum of two (2) vehicles at the Clubhouse.~~
- (2) Patrons swim at their own risk. Lifeguards are not on duty. **Please note that the Swimming Pool and Splash Pad are unattended facilities and persons using the facility do so at their own risk.**
- (3) Children under the age of sixteen (16) years of age must be accompanied by a parent or an adult at least eighteen (18) years of age at all times for usage of the pool facility, which includes the swimming pool, the splash pad, and the pool deck area.
- (4) Radios, televisions, and the like may be listened to if; no offensive music, lyrics or profanity and at a volume that is not offensive to patrons and guests. Electrical equipment is not allowed around the pool facility.
- (5) Swimming is permitted only during designated hours, as posted at the pool facility. Hours are seasonal and subject to change.
- (6) Showers are required before entering the pool or splash pad.
- (7) Glass containers, products, or items are not permitted at the pool facility.
- (8) Children under three (3) years of age and those who are not reliably toilet trained must wear rubber-lined swim diapers, as well as a swim suit over the swim-diaper, to reduce the health risks associated with human waste in the pool facility.
- (9) Play equipment, such as floats, rafts, snorkels, dive sticks, and flotation devices are not permitted in the pool. However, children or persons that are learning to swim are permitted and encouraged to have flotation devices in the pool.
- (10) Pool and splash pad availability may be rotated in order to facilitate maintenance of the Clubhouse.
- (11) Pets, bicycles, skateboards, roller blades, scooters and golf carts are not permitted at the pool facility inside the pool gates at any time.
- (12) The District staff reserves the right to authorize all programs and activities, including the number of guest

participants, equipment and supplies usage, etc., conducted at the pool facility including Swim Lessons and Aquatic/Recreational Programs.

- (13) Any person swimming or using the pool facility when the Clubhouse is closed may be suspended from using the facility. Swimming pool hours will be posted. The swimming pool and splash pad may be closed one day weekly (to be determined) for maintenance. Guests must be registered and accompanied by a Patron before entering the Clubhouse.
- (14) Proper traditional swim attire must be worn in the pool and splash pad. ~~Cut-offs and thong bathing suits are not allowed.~~ Swimwear must be modest and provide reasonable coverage. Transparent or overly revealing attire is prohibited.
- (15) No chewing gum is permitted at the pool facility or on the pool deck area.
- ~~(16) Alcoholic beverages are not permitted at the pool facility.~~
- (17) No diving, jumping, pushing, running or other horseplay is allowed in the pool, splash pad, or on the pool deck area.
- (18) For the comfort of others, the changing of diapers or clothes is not allowed at pool side or at the pool facility.
- (19) No one shall pollute the pool or splash pad to the extent that additional pool treatment, chemicals, water, or services are required to restore the pool to proper standards. Anyone who does pollute the pool is liable for any costs incurred in treating and reopening the pool or splash pad.
- (20) Radio controlled water craft are not allowed in the pool.
- (21) Pool entrances must be kept clear at all times.
- ~~(22) Smoking is not permitted at the Clubhouse or around the pool facility.~~
- ~~(23)~~ No swinging on ladders, fences, or railings is allowed.
- ~~(24)~~ Pool furniture is not to be removed from the pool facility.
- ~~(25)~~ Loud, profane, or abusive language is prohibited.
- ~~(26)~~ Food and drink are not allowed within six (6) feet of the pool or splash pad.
- ~~(27)~~ Skateboarding is not permitted at the Clubhouse, including all parking lots and sidewalks encompassing the Clubhouse facilities.
- ~~(28)~~ Bicycles, skateboards, roller blades, scooters and golf carts are not permitted in the Clubhouse gates. All bicycles must be placed at the bike rack on the west side of the Clubhouse.
- ~~(29) No parties are allowed at the pool facility.~~

E. SWIMMING POOL/SPLASH PAD: THUNDERSTORM POLICY

The Club Manager is in control of the operation of the Pool facility (swimming pool and splash pad) during thunderstorms, heavy rain, and inclement weather. The Club Manager will determine whether swimming is permitted or not during the times when the swimming pool ~~is~~ is attended. During periods of heavy rain, thunderstorms and other inclement weather, the Pool Area will be closed. If heavy rain, thunder or lightning occurs, everyone shall be required to exit the Pool Areas at the first sound of thunder or the first sighting of lightning for a waiting period of at least 30 minutes. At any point during the 30-minute waiting period, if thunder is heard or lightning is seen, the waiting period shall be extended 30 minutes from the last sound of thunder or sighting of lightning.

G. FITNESS CENTER POLICIES

- (1) All Patrons using the Fitness Center are expected to conduct themselves in a responsible, courteous and safe manner in compliance with all policies and rules of the Monterra Community Development District governing the Clubhouse. Disregard or violation of the District's policies and rules and misuse or destruction of Fitness Center equipment may result in the suspension or termination of Fitness Center privileges. Prior to entering the Fitness Center, Patrons are required to register with clubhouse attendant or as otherwise directed. Guests are not permitted in the Fitness Center.
- (2) **Please note that the Fitness Center is an unattended facility and persons using this facility do so at their own risk. Persons interested in using the Fitness Center are encouraged to consult with a physician prior to commencing a fitness program.**
- (3) *Hours:* The Fitness Center is available for use by Patrons during normal operating hours or as otherwise determined by the District.
- (4) *Emergencies:* All emergencies and injuries must be reported to 911 and the Club Manager.
- (5) *Eligible Users:* Patrons sixteen (16) years of age and older are permitted to use the Fitness Center during designated operating hours. A Patron 14 years of age is permitted to use the Fitness Center if accompanied by a Patron 18 years of age or older. Guests are not permitted in the Fitness Center. Persons under the age of eighteen (18) must have an executed Parental Release of Liability Form on file at Clubhouse prior to using the Fitness Center.
- (6) *Proper Attire:* ~~Appropriate clothing athletic attire and closed-toe athletic shoes and footwear (covering the entire foot) must be worn at all times in the Fitness Center. Appropriate clothing includes t-shirts, shorts (no jeans), leotards, and/or sweat suits (no swimsuits).~~ At all times tops and bottoms are required and no exercising in only sports bras or bare chests. Clothing must provide adequate coverage. Street clothes, jeans, cargo shorts, and dress attire are not permitted. Sandals, flip-flops, slippers, or bare feet are prohibited.
- (7) *Food and Beverage:* Food (including chewing gum) is not permitted within the Fitness Center. Beverages, however, are permitted in the Fitness Center if contained in non-breakable containers with screw top or sealed lids.
- (8) *General Policies:*
 - Each individual is responsible for wiping off fitness equipment after use.
 - Use of personal trainers is not permitted in the Fitness Center.
 - Hand chalk is not permitted to be used in the Fitness Center.
 - Radios, tape players and CD players are not permitted unless they are personal units equipped with headphones.
 - No bags, gear, or jackets are permitted on the floor of the Fitness Center or on the fitness equipment.
 - Weights or other fitness equipment may not be removed from the Fitness Center.

- ~~No food or beverage (except water in a capped bottle) is allowed in the Fitness Center.~~
- The use of the fitness equipment shall be on a first come, first serve basis.
- Please limit use of cardiovascular equipment to thirty (30) minutes and step aside between multiple sets on weight equipment if other persons are waiting. If not actively using the fitness equipment, Patron shall move from the fitness equipment to allow others to use.
- Any fitness program operated, established and run by the Club at Monterra may have priority over other users of the Fitness Center.
- ~~Wet~~ B Bathing suits are not allowed in the Fitness Center.
- Patrons of the Fitness Center shall clean up after themselves after using the facility and the equipment, which clean up includes, but is not limited to, removing belongings and towels and properly disposing of garbage, trash, and empty water bottles.
- Strollers and infant carry seats are not allowed in the Fitness Center.

H. TENNIS AND PICKLEBALL COURT POLICIES

- (1) All Patrons and guests using the Tennis and Pickleball Courts are expected to conduct themselves in a responsible, courteous and safe manner in compliance with all policies and rules of the Monterra Community Development District governing the Clubhouse facilities. Disregard or violation of the District's policies and rules and misuse or destruction of Tennis and Pickleball Courts equipment may result in the suspension or termination of Tennis and Pickleball Courts privileges. Guests may use the Tennis and Pickleball Courts if accompanied by an adult Patron.
- (2) **Please note that the Tennis and Pickleball Courts is are an unattended facilityies and persons using the facility do so at their own risk. Persons interested in using the Tennis and Pickleball Courts are encouraged to consult with a physician prior to using the facility. The Tennis and Pickleball Courts is are available for play from sunrise to sunset.**
- (3) *Emergencies:* All emergencies and injuries must be reported to 911, the District Manager, and the Club Manager.
- (4) *Proper Attire:* Proper tennis shoes and attire ~~is~~ are required at all times while on the courts.
- (5) *Availability:* ~~The~~ The Tennis and Pickleball Courts (hereinafter "Courts") are available on a first come, first serve basis and are open for use from dawn to dusk. Each Patron and the Patron's guests are limited to the use of one (1) tennis or pickleball court, respectively for a period no longer than 1 hour when others are waiting. General rules of play apply. ~~No reservations are available.~~
- (6) *General Policies:*
 - Proper tennis and pickleball etiquette shall be adhered to at all times. The use of profanity of disruptive behavior is prohibited.
 - Persons using ~~the~~ the Tennis Courts must supply their own equipment (rackets, balls, etc.).
 - ~~The~~ The Tennis and Pickleball Courts is are intended only for the play of tennis and pickleball accordingly only. Pets, roller blades, bikes, skates, skateboards, and scooters are prohibited from ~~the tennis facility~~ Courts.
 - Beverages are permitted at ~~the~~ the Tennis Courts if contained in non-breakable containers with screw top or sealed lids. No glass containers are permitted on ~~the tennis e~~ the tennis e Courts.
 - No chairs other than those provided by the District are permitted on ~~the tennis e~~ the tennis e Courts.
 - Children under the age of sixteen (16) are not allowed to use ~~the Tennis~~ the Tennis Courts unless accompanied by an adult Patron.
 - Specific rules pertaining to ~~the Tennis~~ the Tennis Courts are posted.

I. TOT LOT POLICIES

- (1) *Hours:* The Tot Lot playground areas shall be available for use from sunrise to sunset.
- (2) Children under the age of ~~thirteen (13)~~ twelve (12) must be accompanied by a parent or authorized person eighteen (18) years old or older.
- (3) Children twelve (12) years of age and older are not permitted to play on the playground equipment.
- (4) No rough housing on the playground.
- (5) Persons using the playground must clean up all food, beverages and miscellaneous trash brought to the playground.
- (6) Use of the playground may be limited from time to time due to a sponsored event, which must be approved by the District Manager.
- (7) The use of profanity or disruptive behavior is prohibited.
- (8) **Please note that the Playground is an unattended facility and persons using the facility do so at their own risk.**

J. BASKETBALL COURT POLICIES

- (1) All Patrons and guests using the Basketball Courts are expected to conduct themselves in a responsible, courteous and safe manner in compliance with all policies and rules of the Monterra Community Development District governing the Clubhouse facilities. Disregard or violation of the District's policies and rules and misuse or destruction of Basketball Court equipment may result in the suspension or termination of Basketball Court privileges. Guests may use the Basketball Courts if accompanied by an adult Patron.
- (2) **Please note that the Basketball Court is an unattended facility and persons using the facility do so at their own risk. Persons interested in using the Basketball Court are encouraged to consult with a physician prior to using the facility.**
- (3) *Eligible Users.* Patrons and guests ~~sixteen (16) years of age and older~~ are permitted to use the Basketball Court only during designated operating hours. Children who are under sixteen (16) years of age may use the Basketball Court only when accompanied by a parent or an authorized person eighteen (18) years of age or older.
- (4) *Hours.* The Basketball Court is available for use from sunrise to sunset. The Courts may not be used for any purpose after dark. If lighting is installed for the Basketball Court in the future, the District Manager shall set the operating hours of the Basketball Court which shall be posted.
- (5) *Emergencies:* For all emergencies call 911 immediately. All emergencies and injuries must also be reported to the Clubhouse Staff as well as the District Operations Manager at 954-721-8681.
- (6) *Proper Attire:* Proper ~~basketball~~ shoes and attire ~~is~~ are required at all times while on the ~~courts~~ Basketball Court.
- (7) *Availability:* The Basketball Court is available on a first come, first serve basis. Patrons and their guests shall limit use of the Basketball Courts to one (1) hour if others are waiting. No reservations available.

(8) *General Policies:*

- a. Proper etiquette shall be adhered to at all times. The use of profanity or disruptive behaviors is prohibited.
- b. Persons using the Basketball Court must supply their own basketball.
- c. The Basketball Courts ~~are~~ is for the play of basketball only.
- d. Beverages are permitted at the Basketball Court if contained in non-breakable containers with screw top or sealed lids. No alcoholic beverages, glass or other breakable items are permitted on the Basketball Court.
- e. No chairs other than those provided by the District are permitted on the Basketball Court.

K. MULTI-PURPOSE ROOM (MPR) RENTAL POLICIES

(1) Patrons may reserve the Multi-Purpose Room (“MPR”) of the Clubhouse for private events. Only a portion of the Clubhouse is available for rental and reservations must be made and approved at least ten (10) business days in advance of the date of intended use and no more than sixty (60) calendar days prior to the date of intended use. Persons interested in doing so should contact Club Manager regarding the anticipated date and time of the event to determine availability. The MPR of the Clubhouse is unavailable for private events on the following holidays:

Easter Sunday	Thanksgiving
Memorial Day Weekend	Christmas Eve
Fourth of July	Christmas Day
Labor Day Weekend	New Year’s Eve
	New Year’s Day

(2) **The Patron renting the MPR shall be responsible for any and all damage and expenses arising from the event.**

(3) *Reservations:* Patrons interested in reserving the MPR must submit a completed MPR Reservation Agreement (the “Reservation Agreement”) to the Club Manager or Club staff for consideration and approval. At the time of approval, separate checks or money orders (NO CASH) for the reservation fee, damage deposit, attendant fee, and security fee, if applicable, made out to the “**Monterra Community Development District**” should be submitted to the Club Manager, as required by the Reservation Agreement, in order to reserve the MPR. Please submit all checks and completed Reservation Agreement to the Club Manager. The Club Manager will review the proposed Reservation Agreement on a case-by-case basis and has the authority to reasonably deny a request. Denial of a request may be appealed by the Patron to the District’s Board of Supervisors for consideration.

Additional hours are available at the per-additional hourly rate.

The rental rates as set forth below include a four (4) hour block of time. Additional hours beyond four (4) are available at the designated per hour rental fee. Rentals do not include furniture, equipment or other items not on the premises (i.e. event tables and chairs).

(4) *Fees and Deposits.* The rental fees and deposits for the use of the District’s facilities for private social gatherings are as follows. If MPR reservations are cancelled within 48 hours of the event, rental and staffing fees will be nonrefundable.

**Club at Monterra Facility Rental Fee
(4 hours)**

	Fee	Deposit
Multi-Purpose Room (MPR)	\$200.00*	\$1,000.00
Cleaning Fee	\$60.00	n/a
Security fee (per hour)	\$16.00	n/a
Additional Hourly Rental Fee (per additional	\$50.00	n/a

hour or any part thereof)

* THE RESERVATION FEE IS NON-REFUNDABLE.

(5) *Refund of Deposit:* To receive a full refund of the deposit, the following must be completed where applicable:

- Ensure that all garbage is removed and placed in the dumpster.
- Remove all displays, favors or remnants of the event.
- Restore the furniture and other items to their original position.
- Wipe off counters, table tops and sink area.
- Replace garbage liner.
- Clean out and wipe down the refrigerator, and all cabinets and used appliances.
- Clean any windows and doors in the rented area.
- Ensure that no damage has occurred to the Clubhouse and its property.
- Patron and Patron's guests are required to adhere to all Clubhouse and pool rules and regulations. Failure to comply with such rules and regulations may result in the forfeiture of Patron's deposit.

(6) *General Policies:*

- Patrons are responsible for ensuring that their guests adhere to the policies set forth herein.
- The volume of live or recorded music must not violate applicable Cooper City or Broward County noise ordinances.
- No glass, breakable items or alcohol are permitted in or around the pool deck area.
- No offensive music, lyrics or profanity is allowed on the Clubhouse premises.
- Notwithstanding, the District may include, in its discretion, additional requirements for rentals as part of the Reservation Agreement.
- No business or commercial use is permitted,

L. SUSPENSION AND REVOCATION OF PRIVILEGES

(1) Membership and use rights and privileges at the Clubhouse of any person (and the benefits of their guests) may be suspended by the Club Manager if, in the sole judgment of the Club Manager, it is determined that the person:

- Submitted false information on the application for a pass or membership.
- Permitted the unauthorized use of a pass.
- Failed to abide by or has violated one or more of these Rules and Policies established for the use of facilities.
- Treated the Club Manager, personnel, employees, and other Patrons of the facilities in an unreasonable or abusive manner.
- Engaged in conduct that is improper or likely to endanger the welfare, safety or reputation of the Clubhouse or its management.
- Injured or harmed or threatened to injure or harm any other person at the Clubhouse, or harmed, destroyed or stolen any personal property on the Clubhouse property or within the Clubhouse, whether belonging to a third party or to Monterra Community Development District.

(2) *Types of Suspension.* Club Manager or District Manager may restrict or suspend, for cause or causes described in the preceding section, privileges of any person to use any or all of the Clubhouse, ~~for such period of time as reasonably determined by Club Manager or District Manager, as the case may be, but for periods no longer than nine (9) months per violation.~~ For the first violation, a written notification of the violation shall be sent to the

Member. For the second violation, the violator shall leave the Clubhouse, or other District facility and not return for at least twenty-four (24) hours after being instructed to leave. For the third violation, a ninety (90) suspension from the Clubhouse or any other District facility in which the violation occurred. For the fourth violation, a suspension from the use of all District facilities for one (1) year from the date of the suspension. In addition, Club Manager or District Manager may suspend some membership rights while allowing a Patron to continue to exercise other membership rights. For example, Club Manager may suspend the rights of a particular Patron (or family member), or Club Manager may prohibit a Patron (or family member) from using the pools or other Club facilities. Any suspension shall be in writing and sent by the Club Manager or District Manager to the suspended person(s) as the address(es) on file with the Clubhouse. No person whose membership privileges have been fully or partially suspended shall on account of any such restriction or suspension be entitled to any refund of Club Assessments, Club Dues, Club Fees, District assessments, or any other fees and charges. During the restriction or suspension, Club Assessments, Club Dues, Club Fees, and District assessments shall continue to accrue and be payable for each billing period. Under no circumstance will a person be reinstated until all amounts due to the Clubhouse and the Monterra Community Development District, including but not limited to any amounts arising out of or in any way connected to damage caused to the Clubhouse by said person, his or her family member(s) or guests, are paid in full.

- (3) *Appeal of Suspension.* Any person suspended by the Club Manager or District Manager pursuant to this Section L may appeal such suspension to the District Board of Supervisors. Appeals must be in writing and shall be filed with the Club Manager or District Manager within forty-five (45) days of the date of the suspension letter. The Board of Supervisors will then schedule the appeal to be heard during the next regularly scheduled public meeting of the Board of Supervisors. However, appeals filed within five (5) business days of the next regularly scheduled Board meeting will be heard at the Board meeting following the next regularly scheduled Board meeting. During the meeting of the Board of Supervisors in which the appeal is to be heard, the person or persons suspended shall appear before the Board. The Board of Supervisors shall have the power to reduce, remove, or impose conditions related thereto, but not increase the length of the suspension.

CLUB AT MONTERRA

RATE SCHEDULE

Fee Type	Amount
Room Rental-Reservation 4 hours (\$50 per additional hour)	\$200.00
Security Deposit	\$1,000.00
Cleaning Fee (4 hours) (\$15 per additional hour)	\$60.00
Security hourly charge	\$16.00
Owner Resident Member MEMBERSHIP Resident (Estada and Apartments 2F excluded)	Paid by CDD Assessment
Non-Resident or Annual Membership	Public Hearing on December 2, 2013 <u>Adopted by Resolution</u>
Membership I.D. Card – new or replacement	\$15.00
Additional Guest Pass	\$15.00

Item #

**Monterra Community Development District
Board of Supervisors Agenda Memorandum
Office of the District Manager**

Meeting Date: July 1, 2026
Subject: Consideration of purchase of two (2) bleacher seating structures for placement at renovated Basketball/Pickleball courts

With the renovation of the Basketball/Pickleball courts the district had thought to reuse the benches that were previously located at the court area to provide seating. Those benches require a concrete pad to be poured to anchor the benches as the asphalt will not properly anchor the benches and could damage the surface.

It has been recommended that the district purchase bleacher seating that can be placed temporarily while permits are processed for permanent installation at the courts. Attached is information related to the bleachers recommended by the engineer as well as additional cost information. I have also included pricing options for similar bleachers from two other vendors.



Lynne Ladner

MONTERRA COMMUNITY DEVELOPMENT DISTRICT

GATE FACILITIES RULE (Part II, General and Procedural Rules)

2.1.1. Use of Gate Facilities. Ingress and Egress in the resident only lane of Gate Facilities is limited to motorized vehicles that have a Gate Access Card. Pedestrians, bicyclists, scooters, and all other non-motorized vehicles are prohibited from entering through the resident only lanes of Gate Facilities and must utilize the pedestrian gate, dedicated bicycle lanes, or, if unable to do so, shall enter through the main entrance providing public access at Pine Island Guardhouse or University Guardhouse, in accordance with Florida Statutes and operation of the Guardhouses by District security personnel.

2.1.2. Violation of Use of Gate Facilities. The first violation of 2.1.1. shall result in a written warning to the Patron or Guest, as such terms are defined in the District's Rules and Policies Regarding Use of the District's Clubhouse Facilities, a second violation shall result in the suspension of Gate Access Card access to the Gate Facilities and membership rights and Clubhouse and Club facilities and a third and subsequent violation may result up to a suspension of one (1) year of Gate Access Card access to the Gate Facilities and membership rights and Clubhouse and Club facilities.

MONTERRA COMMUNITY DEVELOPMENT DISTRICT

DISTRICT PROPERTY RULE (Part III, General and Procedural Rules)

Adopted

3.0 Rule. This rule may be cited and referred to as the Monterra Community Development District Property Rule and shall be codified as Article III of the General and Procedural Rules of the District.

3.1 Stormwater Management Areas

3.1.1. Stormwater Management Areas shall mean lakes, canals and drainage areas, and includes, but are not limited to those tracts of land set forth in the attached map.

3.1.2. The Stormwater Management Areas are not intended for recreational or personal use, and it is strictly prohibited for any unauthorized persons to use the Stormwater Management Areas without the express written permission of the District.

3.1.3. Notwithstanding 3.3.2. above, the following is strictly prohibited by the District: swimming, fishing, boating, removal of any organic or inorganic material or placement of any organic or inorganic material, including but not limited to swimming pool water, trees, shrubs, plants, sod, rocks, cuttings from trees, shrubs, plants, sod, etc..

3.1.4. Any violation of the above shall be considered a trespass of District property and the District Manager has the authority to contact law enforcement personnel to take appropriate legal action, including a charge for trespassing and arrest.

3.1.5. Any violation of the above shall also subject the individual to imposition of all costs and fees associated with the clean up and removal of the offending matter as set forth herein.

3.2. Open Space and Landscape Areas

3.2.1. Open Space and Landscape Areas shall mean the green spaces and landscape areas owned by the District or areas which the District is responsible for maintaining set forth in the attached map.

3.2.2. Open Space and Landscape Areas shall not be utilized as personal property of any individual and following is strictly prohibited by the District: removal of any organic or inorganic material or placement of any organic or inorganic material, including, but not limited to trees, shrubs, plants, sod, rocks and pavers.

3.2.3. Any violation of the above shall subject the individual to imposition of all costs and fees associated with the clean-up and removal of the offending matter as set forth herein.

3.3. Additional Remedies.

3.3.1. In addition to the remedies set forth in this General Property Rule, the District Manager may suspend the membership rights and Clubhouse and Club facilities rights of any Patron or Guest, including, but not limited to, the deactivation or suspension of ALL club or facility access cards and suspension of Gate Access Card access to Gate Facilities as defined in Gate Facilities Rule for a period of thirty (30) days for a first violation and a for a period of one (1) year for a second and subsequent violation.

3.3.2. Additionally, should any costs or fees imposed pursuant to this Rule remain unpaid after thirty (30) days written notice to any Patron or Guest of the Clubhouse, as such terms are defined in the District's Rules and Policies Regarding Use of the District's Clubhouse Facilities, the District Manager may suspend the membership rights and Clubhouse and Club facilities rights until such time as the unpaid fees are paid to the District, including, but not limited to, the deactivation or suspension of ALL club or facility access cards and suspension of Gate Access Card access to Gate Facilities as defined in Gate Facilities Rule.

3.3 3. The appeal provisions set forth in Section L, entitled "Suspension and Revocation of Privileges" of the District Rules and Policies Regarding Use of the District's Clubhouse Facilities shall apply if the rights under this section are exercised by the District.

3.4. The District Property Rule shall be effective _____.

Ladner, Elizabeth

From: Peter Pellerito <PPellerito@millerlegg.com>
Sent: Thursday, June 18, 2026 5:22 PM
To: Jason Weinrub; Colin Branson
Cc: Ladner, Elizabeth; Pete Monzon; Keith Schriener; Adelson Georges; Monterra Clubhouse Manager; Dakota Harp; 06-00168 Monterra CDD
Subject: RE: [EXTERNAL] Re: Benches for Basketball/Pickleball courts
Attachments: BLCH-4TRG_SPEC.pdf; BLCH-2TRG_SPEC.pdf

This message is from an external sender. DO NOT CLICK on links or attachments unless you recognize the sender and know the content is safe.

Lynne

Following discussions regarding the bench and bleacher options for the Monterra Pickleball Court Project, the recommended approach is to complete the current permitted improvements and obtain project closeout prior to pursuing any permanent fix mounted spectator seating improvements.

The primary objective is to avoid delays associated with plan revisions, engineering, permitting, and additional inspections that could significantly impact completion of the current project.

Recommended Approach

- Complete all remaining work under the current permit, including grading, sod installation, fence line restoration, acrylic surfacing, and final inspections (in speaking with Colon, assuming no weather delays, end of June to complete)
- Return the existing benches to the District as originally contemplated.
- Do not install permanent bench foundations or anchorage as part of the current permit.
- Obtain final project closeout and approval from the City.
- Place existing benches at end of court for temporary use
- Evaluate spectator seating as a separate follow-up improvement after permit closeout.

Existing Benches

- The existing benches were originally anchored to concrete foundations.
- Permanent installation of the relocated benches would require new concrete pads and anchorage systems.
- Installation of concrete foundations would likely require plan revisions, permitting review, and additional inspections.
- The cost of engineering, foundations, anchorage, and installation is anticipated to exceed the cost of new pre-engineered seating systems.

Preferred Seating Alternative

- Pre-engineered tip-and-roll bleachers are recommended for consideration, and would necessitate CDD preference of size and possibly color section color.

- Refer to attached shop drawing of product manufactured bleachers
 - 15'-3row \$2,482;
 - 15'-2row \$1,938 per website www.jayprosports.com (equipment cost only)
- Portable bleachers provide flexibility for court operations and maintenance.
- Bleachers can be relocated or stored during storm events if necessary.
- Future installation can be completed under a separate minor improvement effort without impacting the current project schedule.
- Permanent secured bleachers are available in the event District deems fixed bleachers are necessary and would necessitate a concrete pad to anchor.

This approach allows the courts to be completed and opened for use without further delay while providing the District flexibility to evaluate and implement a long-term seating solution at a later date.

Please let me know if you have any questions or require additional information

Regards,

Peter Pellerito, P.E.

Sr. Engineer

Miller-Legg

13680 N.W. 5th Street, Suite 200

Sunrise, Florida 33325

d | (954) 628-3616 ○ | (954) 436-7000 c | (239) 410-2394

From: Jason Weinrub <jason.weinrub@monterracdd.com>

Sent: Thursday, June 18, 2026 3:10 PM

To: Peter Pellerito <PPellerito@millerlegg.com>; Colin Branson <colin@synturfintl.com>

Cc: Ladner, Elizabeth <lladner@inframark.com>; Pete Monzon <pete@jdsasphalt.com>; Keith Schriener <kschriener@millerlegg.com>; Adelson Georges <ageorges@kss1.com>; Monterra Clubhouse Manager <clubhousemanager@monterracdd.com>; Dakota Harp <dakota@synturfintl.com>; Daniel Bates <daniel.bates@hfwcompanies.com>; 06-00168 Monterra CDD <06-00168@millerlegg.com>

Subject: RE: [EXTERNAL] Re: Benches for Basketball/Pickleball courts

Peter are you suggesting based on your email below, that we would have to go through additional permitting to make this happen? Please respond ASAP. I have follow ups based on your response

From: Peter Pellerito <PPellerito@millerlegg.com>

Sent: Thursday, June 18, 2026 2:20 PM

To: Colin Branson <colin@synturfintl.com>; Jason Weinrub <jason.weinrub@monterracdd.com>

Cc: Ladner, Elizabeth <lladner@inframark.com>; Pete Monzon <pete@jdsasphalt.com>; Keith Schriener <kschriener@millerlegg.com>; Adelson Georges <ageorges@kss1.com>; Monterra Clubhouse Manager <clubhousemanager@monterracdd.com>; Dakota Harp <dakota@synturfintl.com>; Daniel Bates <daniel.bates@hfwcompanies.com>; 06-00168 Monterra CDD <06-00168@millerlegg.com>

Subject: RE: [EXTERNAL] Re: Benches for Basketball/Pickleball courts

Colon

Thank you for providing the photographs.

Based on the photos, the existing benches are anchored to concrete foundations. Anchoring the relocated benches directly to the asphalt pavement is not recommended, as it is unlikely to provide a sufficiently secure installation and may create long-term maintenance issues associated with pavement cracking, loosening of anchors, and surface deterioration around the bench locations.

It is recommended that the relocated benches be installed on concrete pads. At a minimum, a saw-cut opening should be provided within the asphalt surface and a concrete slab installed at each bench location. The concrete slab should be a minimum of 4 inches thick and extend at least 8 inches beyond the footprint of each bench leg in all directions. Bench anchors should be installed into the concrete slab in accordance with the bench manufacturer's recommendations.

This approach is more consistent with the existing installation and will provide a more durable and maintainable long-term solution.

Please let me know if you have any questions or require additional information

Regards

Peter Pellerito, P.E.

Sr. Engineer

Miller-Legg

13680 N.W. 5th Street, Suite 200

Sunrise, Florida 33325

d | (954) 628-3616 o | (954) 436-7000 c | (239) 410-2394

From: Colin Branson <colin@synturfintl.com>

Sent: Thursday, June 18, 2026 9:03 AM

To: Jason Weinrub <jason.weinrub@monterracdd.com>

Cc: Ladner, Elizabeth <lladner@inframark.com>; Pete Monzon <pete@idsasphalt.com>; Peter Pellerito <PPellerito@millerlegg.com>; Keith Schriener <kschriener@millerlegg.com>; Adelson Georges <ageorges@kss1.com>; Monterra Clubhouse Manager <clubhousemanager@monterracdd.com>; Dakota Harp <dakota@synturfintl.com>

Subject: Re: [EXTERNAL] Re: Benches for Basketball/Pickleball courts

Good morning,

Please see attached pictures of how your existing benches are installed

Regards

Colin Branson





Experience A Greener World

Colin Branson - Synthetic Turf International

O: 954.433.6608

C: 650.898.2177

www.stiofsouthflorida.com

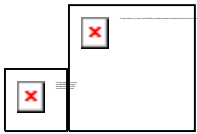

On Wed, Jun 17, 2026 at 8:51 PM Jason Weinrub <jason.weinrub@monterracdd.com> wrote:

Peter P or Keith, please let us know if the first option is feasible so we can move forward without any more delays.

Jason

Get [Outlook for iOS](#)

From: Colin Branson <colin@synturfintl.com>
Sent: Wednesday, 17 June 2026 19:47:26
To: Ladner, Elizabeth <lladner@inframark.com>
Cc: Pete Monzon <pete@jdsasphalt.com>; ppellerito@millerlegg.com <ppellerito@millerlegg.com>; kschriner@millerlegg.com <kschriner@millerlegg.com>; Jason Weinrub <jason.weinrub@monterracdd.com>; Adelson Georges <ageorges@kss1.com>; Monterra Clubhouse Manager <clubhousemanager@monterracdd.com>; Dakota Harp <dakota@synturfintl.com>
Subject: Re: [EXTERNAL] Re: Benches for Basketball/Pickleball courts

Hi everyone,

I have spoken with Keith and Jason regarding the bench installation. While the emails from February indicated that the benches should be moved to the opposite ends of the court, there was no clear confirmation on whether our team or yours would handle the final installation once the court was completed.

Currently, this is not in our scope of work; the plans specifically stated that the benches were to be removed and returned to the owner. Had we been asked to perform the installation initially, it would have required a change order and plan revisions submitted to the city, likely causing delays.

However, after discussing this with my team, we are happy to accommodate the request and secure the benches for you at no additional charge. Our proposed method is to drill into the asphalt, bolt them down, and apply a sealant to prevent water seepage. I suggest performing this work after the court installation is finished and all inspections have passed.

Alternatively, we could issue a change order to postpone the acrylic portion of the project, alter the plans, and submit them to the city to install concrete footers. Please note that this option would delay the project significantly due to the permitting process.

Please let me know how you would like to proceed and I will put together an RFI

Regards,
Colin Branson

Experience A Greener World

Colin Branson - Synthetic Turf International

O: 954.433.6608

C: 650.898.2177

www.stiofsouthflorida.com



On Wed, Jun 17, 2026 at 1:05 PM Ladner, Elizabeth <lladner@inframark.com> wrote:

Colin,

Please work with Peter and Keith to complete the reinstallation.

Lynne Ladner

District Manager

Monterra Community Development District

lladner@inframark.com

cell: 561-446-4821

All topics requested to be brought before the Monterra CDD Board of Supervisors must be submitted to the District Manager by 3 PM on the 3rd Friday of the month before the regularly scheduled board meeting. All supporting documentation must be included with the topic submission. Any topic or submission that is submitted after this deadline will be deferred to the next regular board meeting. Please contact me with any questions.

From: Colin Branson <colin@synturfintl.com>
Sent: Wednesday, June 17, 2026 11:37 AM
To: Ladner, Elizabeth <lladner@inframark.com>
Cc: Pete Monzon <pete@jdsasphalt.com>; ppellerito@millerlegg.com; kschriner@millerlegg.com; jason.weinrub@monterracdd.com; Adelson Georges <ageorges@kss1.com>; clubhouse manager <clubhousemanager@monterracdd.com>
Subject: [EXTERNAL] Re: Benches for Basketball/Pickleball courts

This message is from an external sender. DO NOT CLICK on links or attachments unless you recognize the sender and know the content is safe.

Dear Lynne,

We followed engineering plans provided by Miller Legg, which directed us to remove the existing benches and return them to the owner, we have placed the benches at the top of the staircase near the court entrance.

We can reinstall and secure them at the ends of the courts once the current installation is complete. Please let us know if you would like us to proceed with this.

Regards,
Colin Branson

Experience A Greener World

Colin Branson - Synthetic Turf International

O: 954.433.6608

C: 650.898.2177

www.stiofsouthflorida.com

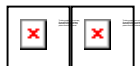

On Wed, Jun 17, 2026 at 10:53 AM Ladner, Elizabeth <lladner@inframark.com> wrote:

Good morning,

It has been brought to my attention that the issue with benches/seating for the new basketball and pickleball courts is in question. Attached is the email chain from February where the decision was made and a drawing provided for the reuse of the benches that had previously been located at the basketball courts. Please let me know why we are now being told that there are not any plans for seating at the courts. As we were reusing the benches that were owned by the CDD where were they stored? Please let me know ASAP where the disconnect on this issue occurred and how to ensure that it is resolved before the courts open. Thank you.

Lynne Ladner

District Manager

Monterra Community Development District

lladner@inframark.com

cell: 561-446-4821

All topics requested to be brought before the Monterra CDD Board of Supervisors must be submitted to the District Manager by 3 PM on the 3rd Friday of the month before the regularly scheduled board meeting. All supporting documentation must be included with the topic submission. Any topic or submission that is submitted after this deadline will be deferred to the next regular board meeting. Please contact me with any questions.

----- Forwarded message -----

From: "Ladner, Elizabeth" <lladner@inframark.com>

To: Peter Pellerito <PPellerito@millerlegg.com>, Keith Schriener <kschriener@millerlegg.com>, Colin Branson <colin@synturfintl.com>

Cc: Jessica Romer <jromer@millerlegg.com>, 06-00168 Monterra CDD <06-00168@millerlegg.com>

Bcc:

Date: Wed, 25 Feb 2026 15:29:28 +0000

Subject: RE: Monterra CDD Basketball/Pickleball Impr (CCC Permit)

Peter,

Thank you for checking. Let's proceed with placing the benches at either end of the project as was shown in the diagram yesterday.

Lynne Ladner

District Manager

Monterra Community Development District

lladner@inframark.com

cell: 561-446-4821

All topics requested to be brought before the Monterra CDD Board of Supervisors must be submitted to the District Manager by 3 PM on the 3rd Friday of the month before the regularly scheduled board meeting. All supporting documentation must be included with the topic submission. Any topic or submission that is submitted after this deadline will be deferred to the next regular board meeting. Please contact me with any questions.

From: Peter Pellerito <PPellerito@millerlegg.com>

Sent: Wednesday, February 25, 2026 8:53 AM

To: Ladner, Elizabeth <lladner@inframark.com>; Keith Schriener <kschriener@millerlegg.com>; Colin Branson <colin@synturfintl.com>

Cc: Jessica Romer <jromer@millerlegg.com>; 06-00168 Monterra CDD <06-00168@millerlegg.com>

Subject: RE: Monterra CDD Basketball/Pickleball Impr (CCC Permit)

Lynn

Benches located in these areas present a safety concern. A 5-foot setback is already below the preferred safety buffer, where a minimum of 10 feet is recommended. Introducing obstructions within this reduced buffer zone — including benches, spectators, and associated equipment — increases the risk of player collisions and injury.

Placement at the ends of the courts represents the safer and more appropriate option.

Please let me know if you have any questions or require additional information

Regards

Peter Pellerito, P.E.

Sr. Engineer

Miller-Legg

[13680 N.W. 5th Street, Suite 200](#)

Sunrise, Florida 33325

d | (954) 628-3616 o | (954) 436-7000 c | (239) 410-2394

From: Ladner, Elizabeth <lladner@inframark.com>

Sent: Tuesday, February 24, 2026 4:22 PM

To: Keith Schriner <kschriner@millerlegg.com>; Peter Pellerito <PPellerito@millerlegg.com>; Colin Branson

<colin@synturfintl.com>

Cc: Jessica Romer <jromer@millerlegg.com>; 06-00168 Monterra CDD <06-00168@millerlegg.com>

Subject: RE: Monterra CDD Basketball/Pickleball Impr (CCC Permit)

Keith, Colin, and Peter,

I spoke with the board chair and he thought if it is possible to put the benches back to back on either side of the divider fence between the basketball court and the pickleball courts that would be his preference but if that is not possible without issues for the courts and their layout than we definitely want the benches and to install two benches on each end as shown in the figure below.

Lynne Ladner

District Manager

Monterra Community Development District

lladner@inframark.com

cell: 561-446-4821

All topics requested to be brought before the Monterra CDD Board of Supervisors must be submitted to the District Manager by 3 PM on the 3rd Friday of the month before the regularly scheduled board meeting. All supporting documentation must be included with the topic submission. Any topic or submission that is submitted after this deadline will be deferred to the next regular board meeting. Please contact me with any questions.

From: Keith Schriener <kschriner@millerlegg.com>

Sent: Tuesday, February 24, 2026 2:49 PM

To: Ladner, Elizabeth <lladner@inframark.com>; Peter Pellerito <PPellerito@millerlegg.com>; Colin Branson <colin@synturfintl.com>

Cc: Jessica Romer <jromer@millerlegg.com>; 06-00168 Monterra CDD <06-00168@millerlegg.com>

Subject: RE: Monterra CDD Basketball/Pickleball Impr (CCC Permit)

Good afternoon,

New benches were not part of the scope. The plans call for the existing benches to be returned to Owner, but they can be reinstalled at the locations shown in **RED** below.

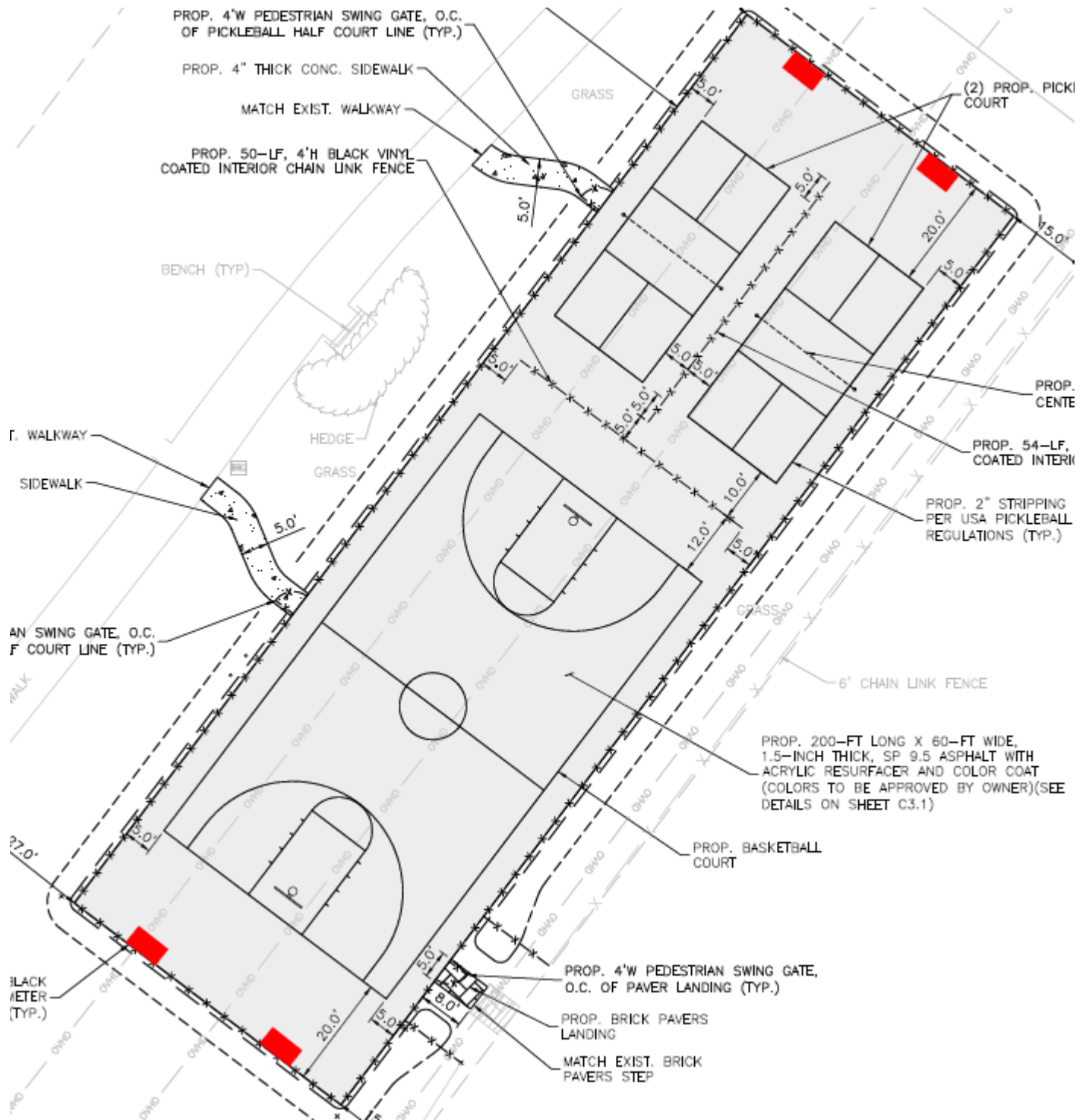

Sincerely,

Keith R. Schriener

Civil Engineer II



Improving Communities. Creating Environments.

[13680 NW 5th Street, Suite 200, Sunrise, FL 33325](#)

d | (954) 440-5039 o | (954) 436-7000 x5039



www.millerlegg.com

From: Ladner, Elizabeth <lladner@inframark.com>
Sent: Tuesday, February 24, 2026 12:41 PM
To: Peter Pellerito <PPellerito@millerlegg.com>; Keith Schriener <kschriner@millerlegg.com>; Colin Branson <colin@synturfintl.com>
Cc: Jessica Romer <jromer@millerlegg.com>; 06-00168 Monterra CDD <06-00168@millerlegg.com>
Subject: RE: Monterra CDD Basketball/Pickleball Impr (CCC Permit)

Keith and Peter,

Unless there are new benches included in the approved project, I believe the best solution would be to reuse the existing benches.

Lynne Ladner

District Manager

Monterra Community Development District

lladner@inframark.com

cell: 561-446-4821

All topics requested to be brought before the Monterra CDD Board of Supervisors must be submitted to the District Manager by 3 PM on the 3rd Friday of the month before the regularly scheduled board meeting. All supporting documentation must be included with the topic submission. Any topic or submission that is submitted after this deadline will be deferred to the next regular board meeting. Please contact me with any questions.

From: Peter Pellerito <PPellerito@millerlegg.com>
Sent: Tuesday, February 24, 2026 8:19 AM
To: Keith Schriener <kschriner@millerlegg.com>; Ladner, Elizabeth <lladner@inframark.com>; Colin Branson <colin@synturfintl.com>
Cc: Jessica Romer <jromer@millerlegg.com>; 06-00168 Monterra CDD <06-00168@millerlegg.com>
Subject: RE: Monterra CDD Basketball/Pickleball Impr (CCC Permit)

The DM will need to weigh in on the final placement; however, unless otherwise directed, please proceed with coordinating with the contractor to place it at the end as stated.

Peter Pellerito, P.E.

Sr. Engineer

Miller-Legg

[13680 N.W. 5th Street, Suite 200](#)

Sunrise, Florida 33325

d | (954) 628-3616 o | (954) 436-7000 c | (239) 410-2394

From: Keith Schriener <kschriner@millerlegg.com>

Sent: Thursday, February 5, 2026 4:37 PM

To: Ladner, Elizabeth <lladner@inframark.com>; Colin Branson <colin@synturfintl.com>

Cc: Peter Pellerito <PPellerito@millerlegg.com>; Jessica Romer <jromer@millerlegg.com>; 06-00168 Monterra CDD <06-00168@millerlegg.com>

Subject: RE: Monterra CDD Basketball/Pickleball Impr (CCC Permit)

Lynn/Peter,

One thing that came up at the pre-con was about the two existing benches. The plans currently call for them “to be removed and returned to owner.” Does the CDD want these re-installed inside the fenced in area or did you want to go with a different product? See below where I’d recommend they get placed and bolted inside the court if you want them reinstalled. If we spec’ a different product, we can do two at each end. Please provide your input.

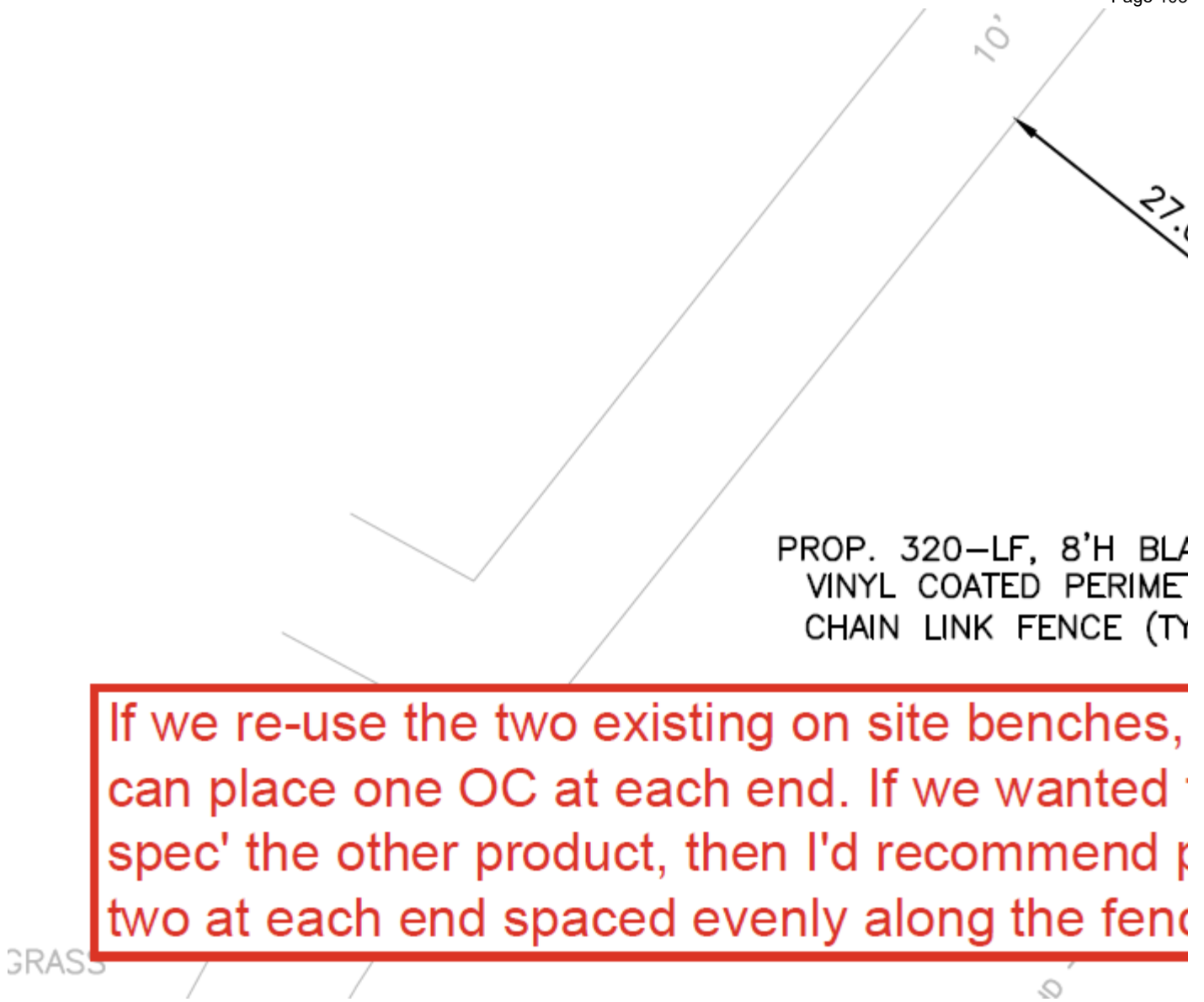

If we re-use the two existing on site benches, can place one OC at each end. If we wanted spec' the other product, then I'd recommend two at each end spaced evenly along the fence

Other product – similar metal bleachers but a single bench unit.

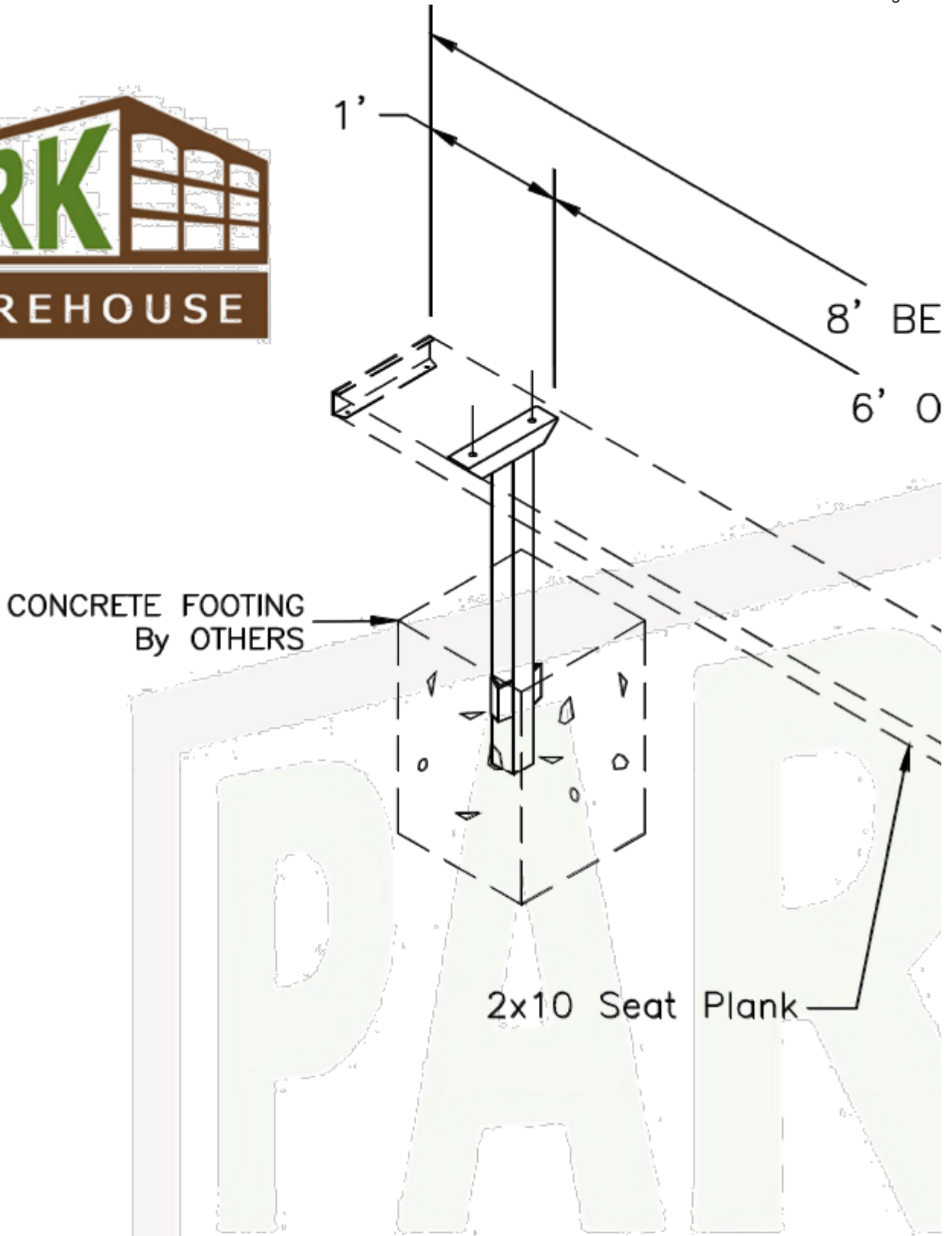

ISOMETRIC VIEW OF BENCH ASSEMBLY

Note: Seat Plank Shown Dotted for Clarity

Kind regards,

Keith R. Schriener

Civil Engineer II



Improving Communities. Creating Environments.

[13680 NW 5th Street, Suite 200, Sunrise, FL 33325](#)

d | (954) 440-5039 o | (954) 436-7000 x5039



www.millerlegg.com

From: Ladner, Elizabeth <lladner@inframark.com>
Sent: Thursday, February 5, 2026 2:40 PM
To: Colin Branson <colin@synturfintl.com>; Keith Schrinier <kschriner@millerlegg.com>
Cc: Peter Pellerito <PPellerito@millerlegg.com>; Jessica Romer <jromer@millerlegg.com>; 06-00168 Monterra CDD <06-00168@millerlegg.com>
Subject: RE: Monterra CDD Basketball/Pickleball Impr (CCC Permit)

Colin,

Please revise the Fencing line item to remove any references to batting cage. Thank you.

Court Surfacing

Court Resurfacing Scope of Work:

- Flood existing court for any ponding.
- Adding of Leveler/Binder to fill any areas.
- Two (2) Coats of Acrylic Resurfacer.
- Two (2) Coats of approved Laykold Standard Colors.

Includes markings for:

- One (1) Basketball Court.
 - Two (2) Pickeball Courts
 - two (2) portable Pickleball Nets
-

Basketball Goal Post

-Furnish and Install:

- Two (2) New Adjustable Basketball system(Poles , Backboard, Rims & Nets)
-

Court Fencing

Approx 540 LinFt of fencing 8' high to be installed around perimeter of basketball court **and batting cage**

Concrete

Additional concrete work to be done: 2 concrete walkways

Walkway 1 - 38' x 5' x4" and

Walkway 2 - 35' x 5' x4"

4 concrete slabs 4' x 7' for benches along the court.

Lynne Ladner
District Manager

Monterra Community Development District

lladner@inframark.com

cell: 561-446-4821

All topics requested to be brought before the Monterra CDD Board of Supervisors must be submitted to the District Manager by 3 PM on the 3rd Friday of the month before the regularly scheduled board meeting. All supporting documentation must be included with the topic submission. Any topic or submission that is submitted after this deadline will be deferred to the next regular board meeting. Please contact me with any questions.

From: Colin Branson <colin@synturfintl.com>

Sent: Thursday, February 5, 2026 2:23 PM

To: Keith Schriener <kschriner@millerlegg.com>

Cc: Ladner, Elizabeth <lladner@inframark.com>; Peter Pellerito <PPellerito@millerlegg.com>; Jessica Romer <jromer@millerlegg.com>; 06-00168 Monterra CDD <06-00168@millerlegg.com>

Subject: Re: Monterra CDD Basketball/Pickleball Impr (CCC Permit)

Hi Keith,

Please find the attached itemized quote for your review.

As discussed during our site visit with Jessica, the fencing price has increased due to rising material costs and the additional labor required for the interior court fencing.

Regarding the concrete work, the plans specify the removal and replacement of two walkways. We have confirmed the site measurements as 38' x 5' and 35' x 5', both at a 4" thickness. This scope also includes the removal of four existing 4' x 7' concrete slabs to accommodate the benches along the court.

Please let me know if you have any questions.

Best regards,

Colin Branson

Experience A Greener World

Colin Branson - Synthetic Turf International

O: 954.433.6608

C: 650.898.2177

www.stiofsouthflorida.com



On Thu, Feb 5, 2026 at 9:11 AM Keith Schriener <kschriner@millerlegg.com> wrote:

Good morning,

The increase was in the fencing total (+\$5,175) and the additional line item for concrete (\$4,565) for a total increase of \$9740 – see below snippets.

That being said, the scope for your fencing line item description is off. The plans call for approximately 320-LF, 8-ft high perimeter fencing and a total of 104-LF, 4-ft high interior fencing (no batting cage that I'm aware of). Seems like there could be a deduct considering you previously quoted 540-LF, 12-ft high fence. Please provide one line item for each fence height so we can compare pricing.

Please provide a quantity in your line item for the concrete. To answer one of your questions in the email thread. There's no concrete boarder around the new court. The fence will be placed at the edge of pavement and the grade will stay flat for 1-ft offset before grading down to existing grade at 4:1.

We can get on a call sometime today if needs be.

Original Quote

Court Fencing

Approx 540 LinFt of fencing 12' high to be installed around perimeter of basketball court and batting cage

Thank you for the opportunity to work with you! Please let us know if you have any questions or need anything else! - Thank you for considering Synthetic Turf Intl Group!

SL
TA

New Quote

Court Fencing

Approx 540 LinFt of fencing 12' high to be installed around perimeter of basketball court and batting cage

Concrete

Additional concrete work to be done to the concrete walkways and the 4 concrete benches

Thank you for the opportunity to work with you! Please let us know if you have

SU

Kind regards,

Keith R. Schriener

Civil Engineer II



Improving Communities. Creating Environments.

13680 NW 5th Street, Suite 200, Sunrise, FL 33325

d | (954) 440-5039 o | (954) 436-7000 x5039



www.millerlegg.com

From: Ladner, Elizabeth <ladner@inframark.com>

Sent: Thursday, February 5, 2026 8:20 AM

To: Colin Branson <colin@synturfintl.com>; Peter Pellerito <PPellerito@millerlegg.com>
Cc: Keith Schriener <kschriner@millerlegg.com>; 06-00168 Monterra CDD <06-00168@millerlegg.com>
Subject: RE: Monterra CDD Basketball/Pickleball Impr (CCC Permit)

Colin,

Can you please provide me with documentation of which lines in the new invoice have been changed and by how much? Thank you

Lynne Ladner

District Manager

Monterra Community Development District

lladner@inframark.com

cell: 561-446-4821

All topics requested to be brought before the Monterra CDD Board of Supervisors must be submitted to the District Manager by 3 PM on the 3rd Friday of the month before the regularly scheduled board meeting. All supporting documentation must be included with the topic submission. Any topic or submission that is submitted after this deadline will be deferred to the next regular board meeting. Please contact me with any questions.

From: Colin Branson <colin@synturfintl.com>
Sent: Wednesday, February 4, 2026 7:53 PM
To: Peter Pellerito <PPellerito@millerlegg.com>
Cc: Ladner, Elizabeth <lladner@inframark.com>; Keith Schriener <kschriner@millerlegg.com>; 06-00168 Monterra CDD <06-00168@millerlegg.com>
Subject: Re: Monterra CDD Basketball/Pickleball Impr (CCC Permit)

Good Evening,

Please find attached the revised estimate for the additional fence and concrete work required for the project.

The initial deposit received was \$38,185. To begin the project, we require a total deposit equal to 50% of the final price. Therefore, an additional deposit of \$47,585 is required to proceed.

Please advise how you would like to proceed. I can send you the invoice and we can work on getting this on the schedule

Best regards,

Colin Branson

Experience A Greener World

Colin Branson - Synthetic Turf International

O: 954.433.6608

C: 650.898.2177

www.stiofsouthflorida.com



On Wed, Feb 4, 2026 at 3:41 PM Peter Pellerito <PPellerito@millerlegg.com> wrote:

Colin

No walkway rails are required. Based on a review of the site photographs, a portion of the existing sidewalk can be salvaged. Only an approximate 12-foot section of sidewalk removal and replacement is necessary to achieve the required 1:12 slope resulting from the 1-ft vertical raised pickleball court elevation. Earthen fill will be placed on both sides of the sidewalk ramp to eliminate any grade differential and avoid drop-off conditions.

Please let me know if you have any questions or require additional information

Peter Pellerito, P.E.

Sr. Engineer

Miller-Legg

[13680 N.W. 5th Street, Suite 200](#)

Sunrise, Florida 33325

d | (954) 628-3616 o | (954) 436-7000 c | (239) 410-2394

From: Colin Branson <colin@synturfintl.com>

Sent: Wednesday, February 4, 2026 2:25 PM

To: Peter Pellerito <PPellerito@millerlegg.com>

Cc: Ladner, Elizabeth <lladner@inframark.com>; Keith Schriener <kschriener@millerlegg.com>; pete jdsasphalt.com <pete@jdsasphalt.com>; 06-00168 Monterra CDD <06-00168@millerlegg.com>

Subject: Re: Monterra CDD Basketball/Pickleball Impr (CCC Permit)

Peter,

Please can you confirm on the plans if we are doing walkway rails on both of the pathways we are building. They are not on the plans but we don't want to have issues after install.

Please confirm so I can finalize pricing

Regards

Colin Branson

Experience A Greener World

Colin Branson - Synthetic Turf International

O: 954.433.6608

C: 650.898.2177

www.stiofsouthflorida.com

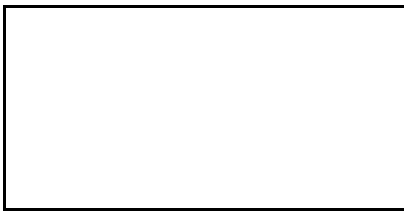

On Tue, Feb 3, 2026 at 4:34 PM Colin Branson <colin@synturfintl.com> wrote:

Please can you resend the plans.

I can't find it in the email thread

Regards

Colin Branson

Experience A Greener World

Colin Branson - Synthetic Turf International

O: 954.433.6608

C: 650.898.2177

www.stiofsouthflorida.com



On Tue, Feb 3, 2026 at 10:45 AM Colin Branson <colin@synturfintl.com> wrote:

We can start within a week or two once we confirm the final scope of work.

After looking at the plans with Jessica there are a couple things we need to adjust. I'm working on pricing for the concrete and the additional work with the fence. It also looks like we will need to do a concrete footer around the entire perimeter of the court.

Can you confirm if you are wanting rails on both walk ways entering to court ?

I will hopefully have the final price for you by end of day today or tomorrow morning.

Regards

Colin Branson

Experience A Greener World

BLCH-2TRG 15' TIP & ROLL BLEACHER

PLANKS ARE SUPPORTED BY A STRONG, ALUMINUM UNDERSTRUCTURE
 TYPICAL TRANSITION FOOT PREVENTS FLOOR MARKING

10" WIDE NON-SKID ALUMINUM PLANKS

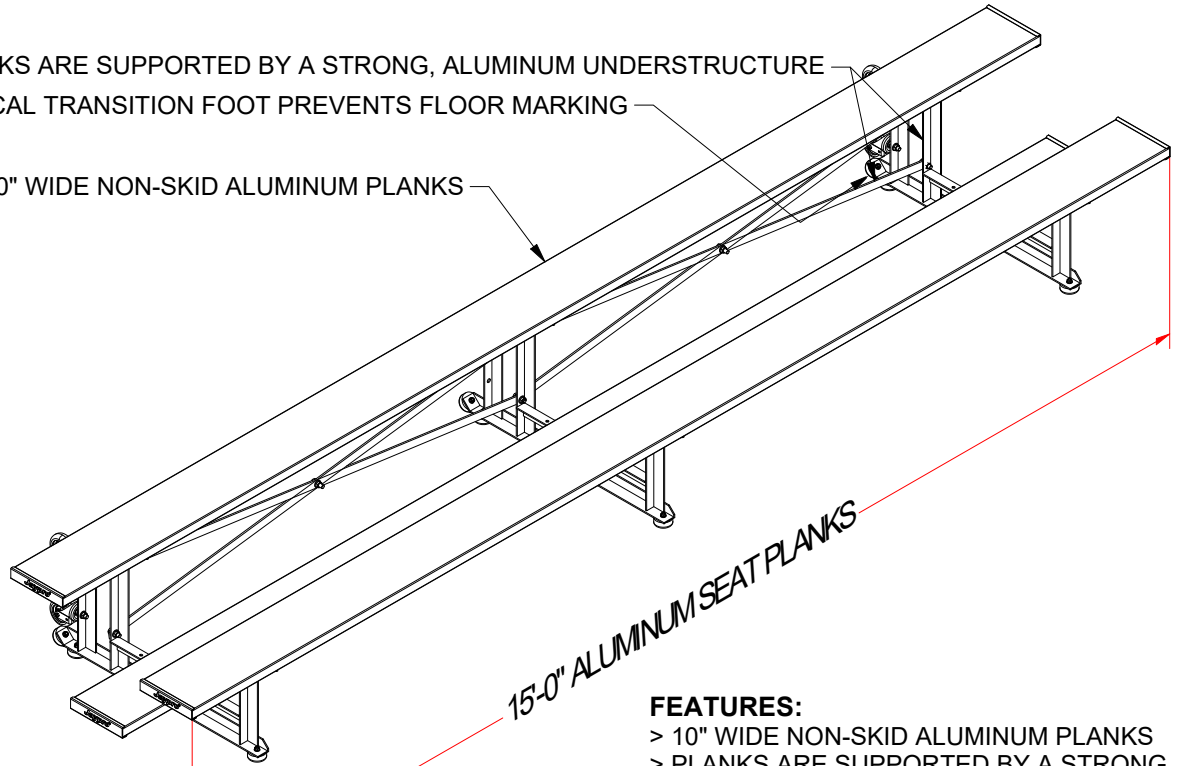

FEATURES:

- > 10" WIDE NON-SKID ALUMINUM PLANKS
- > PLANKS ARE SUPPORTED BY A STRONG, ALUMINUM UNDERSTRUCTURE
- > TRANSITION FOOT PREVENTS FLOOR MARKING
- INCLUDES FOUR 4" NON-MARKING SWIVEL CASTERS

OPTIONS:

- > POWDER COAT YOUR BLEACHER FOR A CUSTOM LOOK! MATCH YOUR SCHOOL COLORS! WHEN ORDERING, PLEASE SPECIFY COLORS FOR PLANKS AND UNDERSTRUCTURE AND ALLOW UP TO FOUR WEEKS FOR DELIVERY

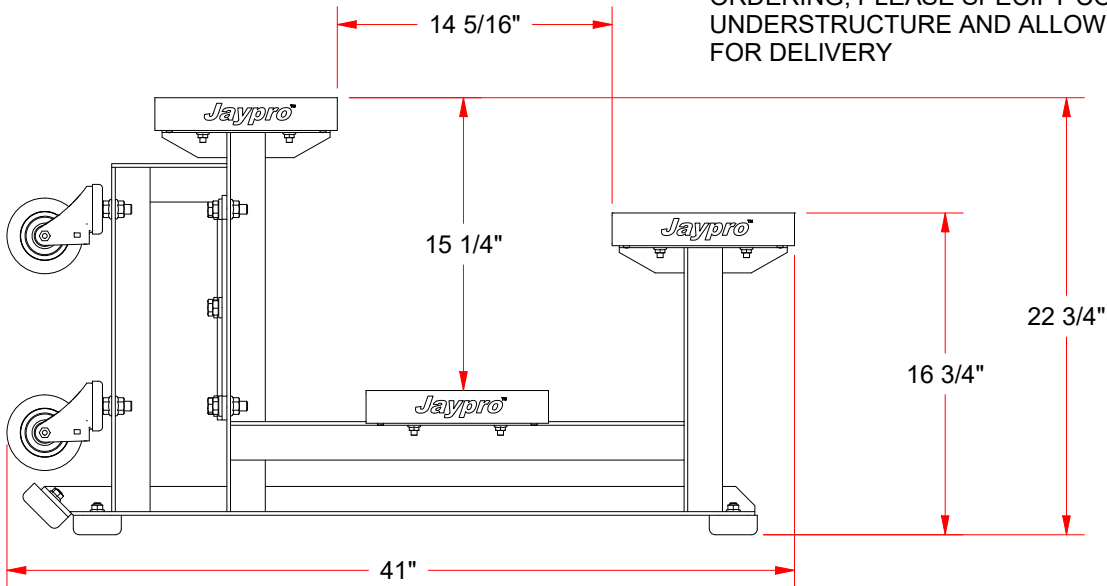

BLCH-2TRG
 15' TIP & ROLL BLEACHER

© COPYRIGHT 2019 JAYPRO SPORTS, LLC. ALL RIGHTS RESERVED THIS PRINT IS THE PROPERTY OF JAYPRO SPORTS, LLC. AND MAY NOT BE REPRODUCED WITHOUT WRITTEN PERMISSION

www.jaypro.com
 (800) 243-0533
 976 Hartford Turnpike
 Waterford, CT 06385 USA

Sheet 1 of 1

BLCH-4TRG

15' TIP & ROLL BLEACHER

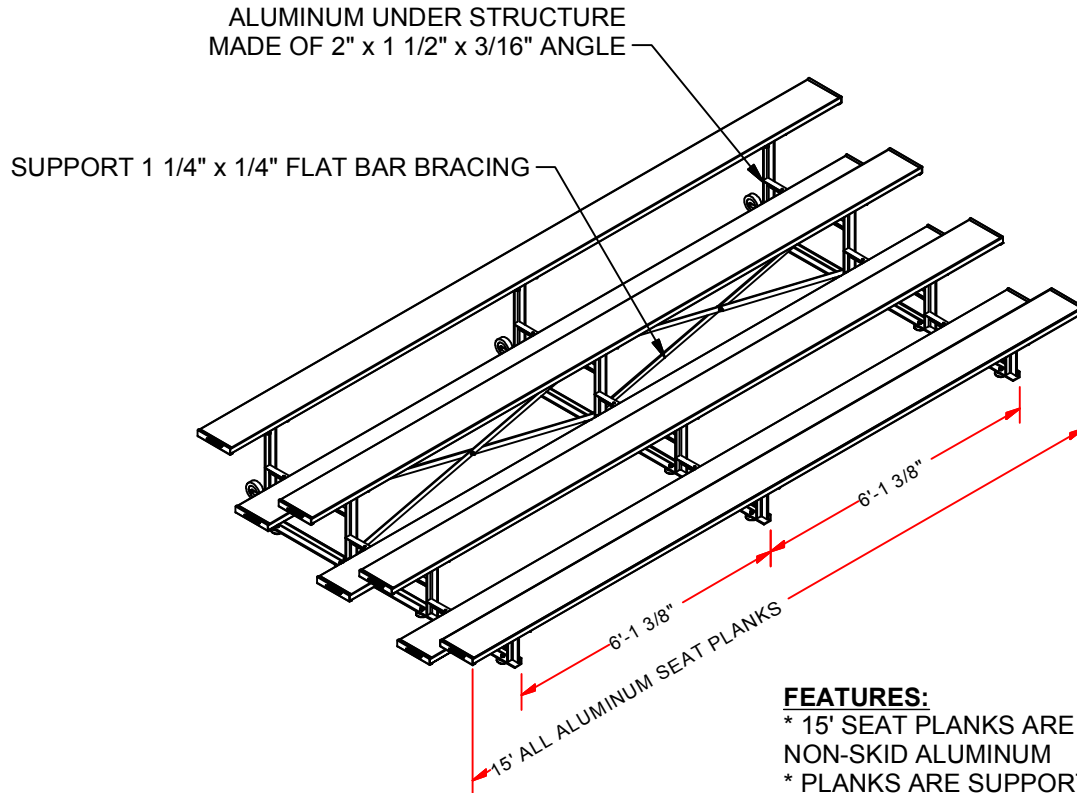

FEATURES:

- * 15' SEAT PLANKS ARE 10" WIDE NON-SKID ALUMINUM
- * PLANKS ARE SUPPORTED BY A STRONG, ALUMINUM UNDERSTRUCTURE
- * EACH LEG SITS ON 4 STURDY RUBBER FEET
- * BLEACHER ROLLS ON (6) 4" DIA HEAVY DUTY CASTER WHEELS

OPTIONS:

- * CUSTOM POWDER COATED COLORS

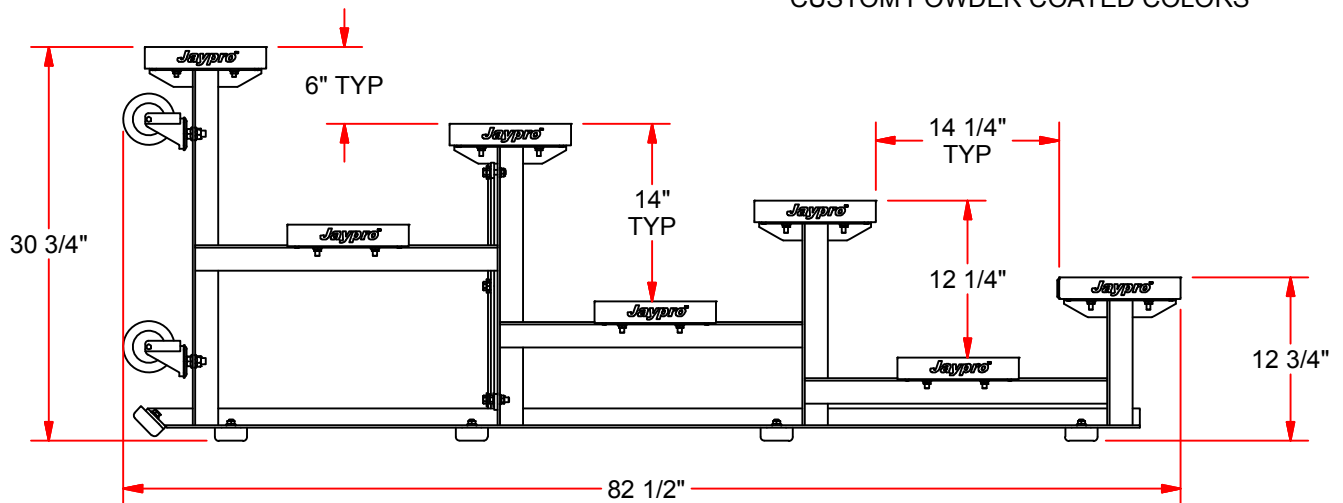

REV.	DESCRIPTION	DATE	BY
-	INITIAL RELEASE	11/11	MT

BLCH-4TRG
15' TIP & ROLL BLEACHER

THIS PRINT IS THE PROPERTY OF JAYPRO SPORTS, LLC. AND MAY NOT BE REPRODUCED WITHOUT WRITTEN PERMISSION

www.jaypro.com



Jaypro
Sports Equipment
Since 1986

FAX: 860.444.1779 (SALES)
860.440.0628 (ENG.)

PHONE: 800.243.0533 (TOLL FREE)
860.447.3001 (LOCAL)

JAYPRO SPORTS, LLC, 976 HARTFORD TURNPIKE, WATERFORD, CT 06385 USA

DRAWING NAME / PART NUMBER: BLCH-4TRG	
DRAWN BY: Moone T.	ISSUE DATE: 11/3/2011
CHK'D BY: WVB	CHK'D DATE: 11/3/2011
SHEET: 1 OF 1	REV. -



BLCH-375TRG 7-1/2' TIP & ROLL BLEACHER

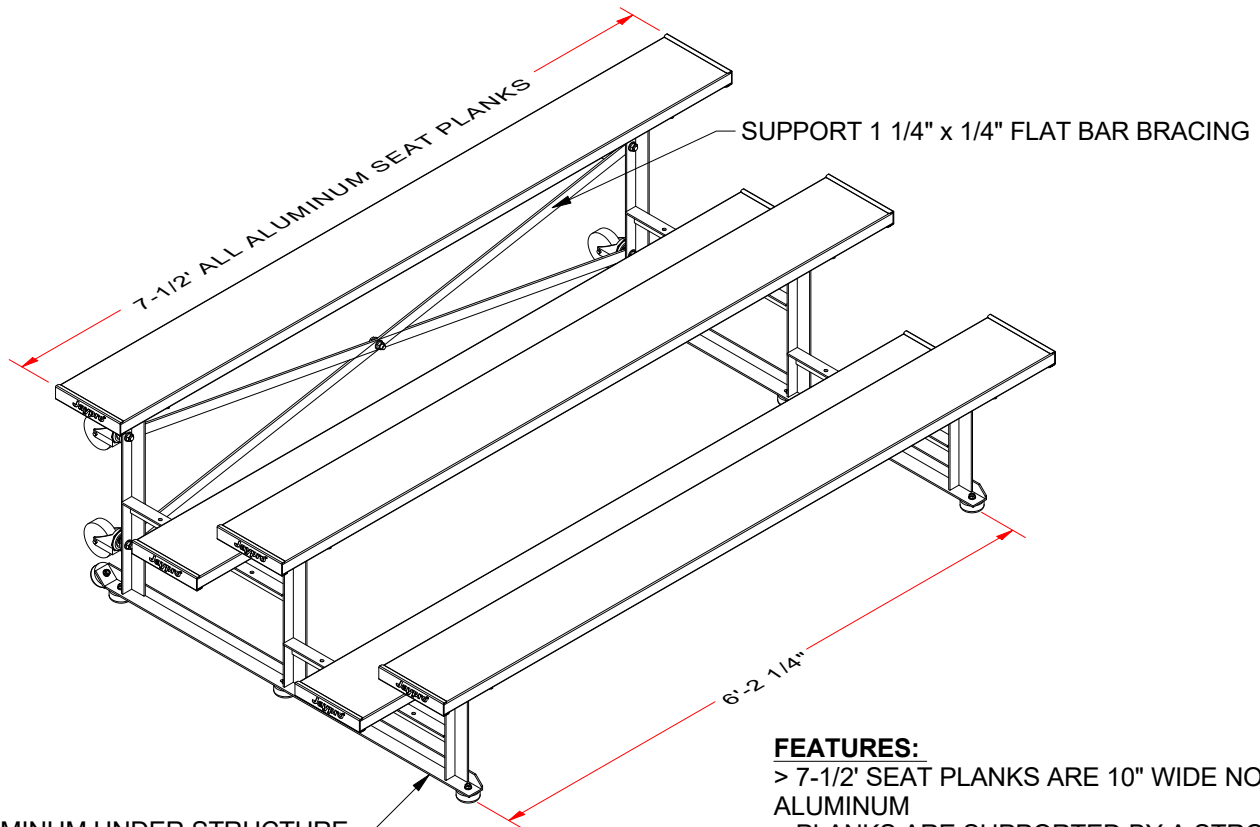

ALUMINUM UNDER STRUCTURE
MADE OF 2" x 1 1/2" x 3/16" ANGLE

FEATURES:

- > 7-1/2' SEAT PLANKS ARE 10" WIDE NON-SKID ALUMINUM
- > PLANKS ARE SUPPORTED BY A STRONG, ALUMINUM UNDERSTRUCTURE
- > EACH LEG SITS ON 3 STURDY RUBBER FEET
- > BLEACHER ROLLS ON (4) 4" DIA HEAVY DUTY CASTER WHEELS

OPTIONS:

- > CUSTOM POWDER COATED COLORS

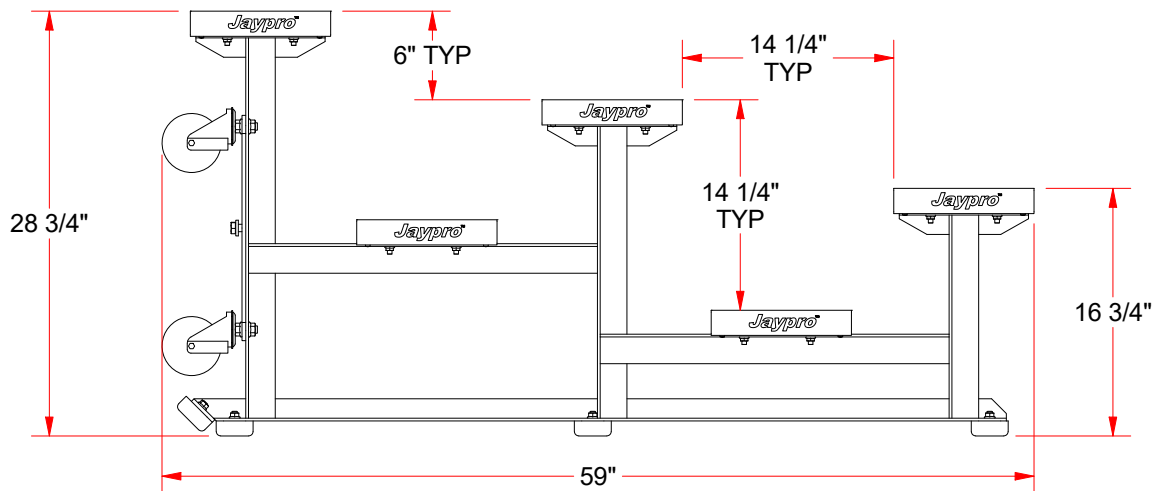

BLCH-375TRG

7-1/2' TIP & ROLL BLEACHER

© COPYRIGHT 2017 JAYPRO SPORTS, LLC. ALL RIGHTS RESERVED
THIS PRINT IS THE PROPERTY OF JAYPRO SPORTS, LLC. AND MAY
NOT BE REPRODUCED WITHOUT WRITTEN PERMISSION

www.jaypro.com
(800) 243-0533
976 Hartford Turnpike
Waterford, CT 06385 USA

Sheet 1 of 1

Click to Print



The Park Catalog
931 Village Blvd Ste 905-354, West
Palm Beach, FL 33409
855-746-5548
noreply@theparkcatalog.com

This item requires a shipping quote.
Please add it to your cart, then click
Request a Quote.

QuickShip  **REQUEST A QUOTE**

Sourcewell 

Awarded Contract

Contract # 081523-NRS

2 Row Tip And Roll Bleachers - Baseline Series



\$1,056.00

BuyBoard *Approved Item* Contract #: 781-25

Request a quote 

Quick Overview

 **Best Price Guarantee**

 **Bulk Discount**

 **Free Expert Consultation**
800-695-3503

Request a quote 

Need Help? Chat with a representative now.

Length

Choose an Option... 

\$1,056.00



2 Row Tip and Roll Bleachers - Baseline Series

Item No: 569-1300

Bleacher Length: 7'-6"

CS.1	- COVER SHEET
TD.1	- BLEACHER SEATING PLAN
BA.1	- BLEACHER ASSEMBLY
PF.1	- PLANK & FRAMING PLAN

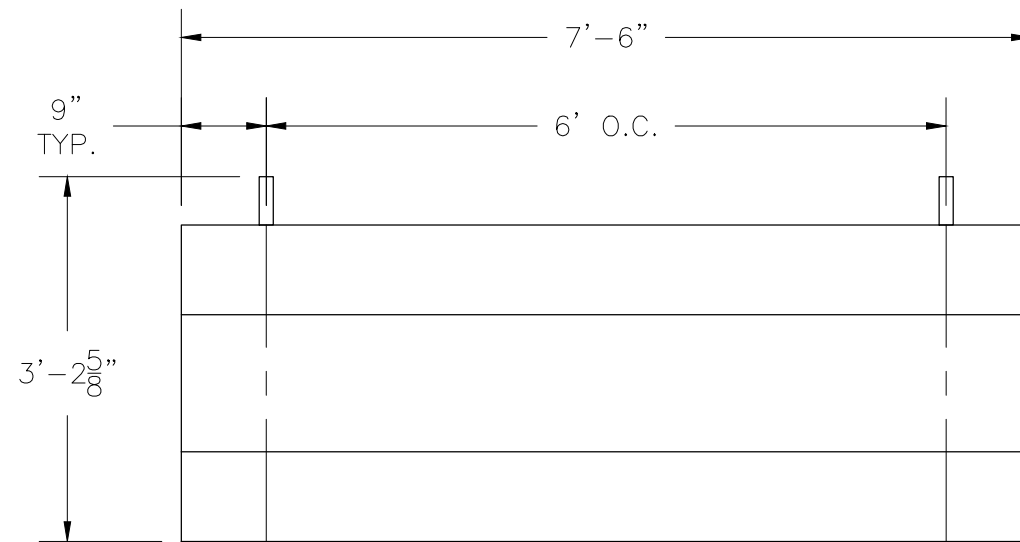

SECTION LENGTH	GROSS SEATS	ACTUAL SEATS	NO. OF ROWS	NET SEATS
7.5	5.00	5.00	2	10
NET SEATS				10
WHEELCHAIR SPACES				0
TOTAL NET SEATING CAPACITY				10
(BASED ON 18" PER SEAT)				

This drawing and all information contained herein is the property of The Park Catalog, and is not to be reproduced without express written permission of this manufacturer. We assume no responsibility for unauthorized use of this drawing. The Park Catalog is not responsible for local permits, local code compliance and occupancy requirements.

SCALE: N.T.S.	APPROVED BY: / /	DRAWN BY:
DATE:	TITLE: Bleacher Seating Plan	
BLEACHER MODEL #:	DRAWING NUMBER: TD.1	

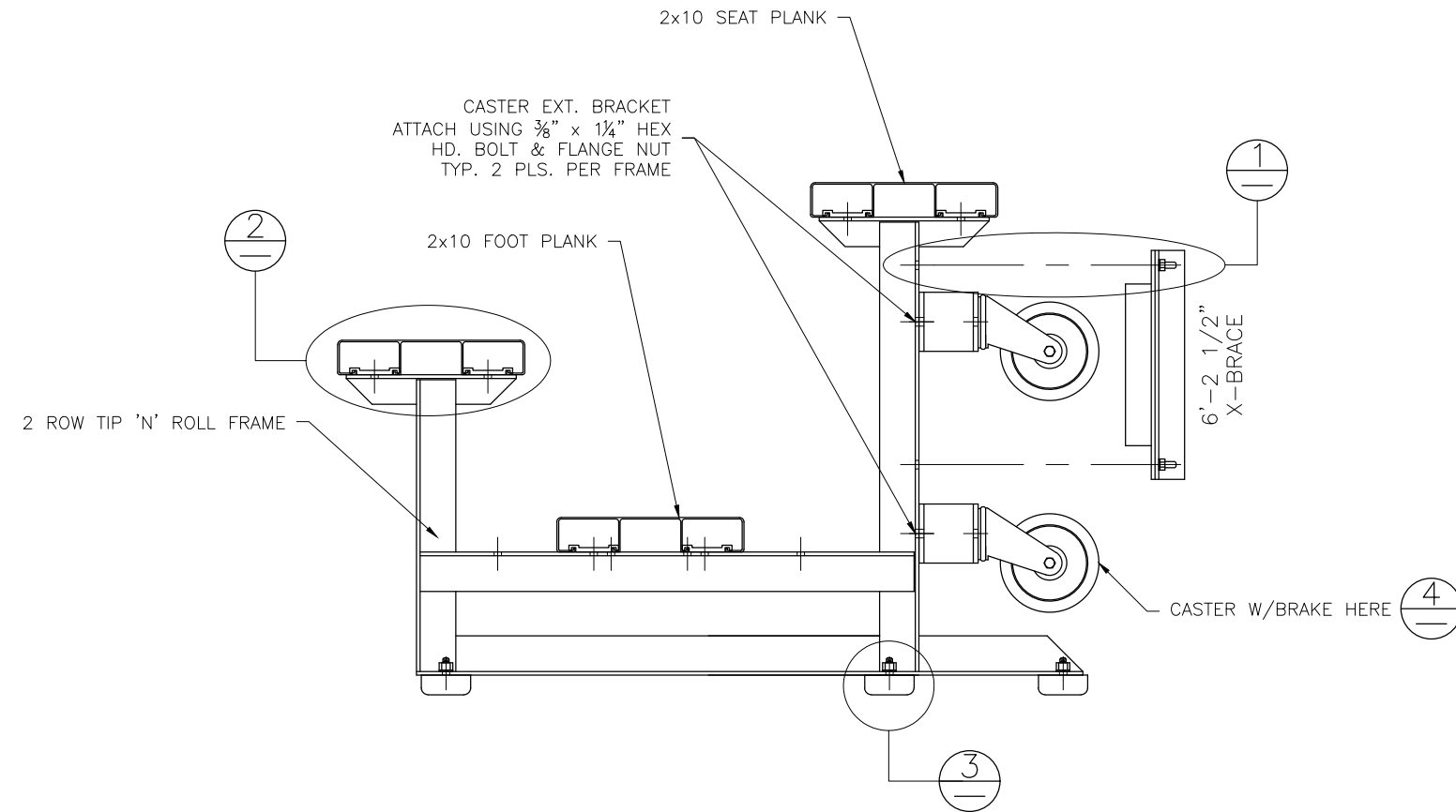
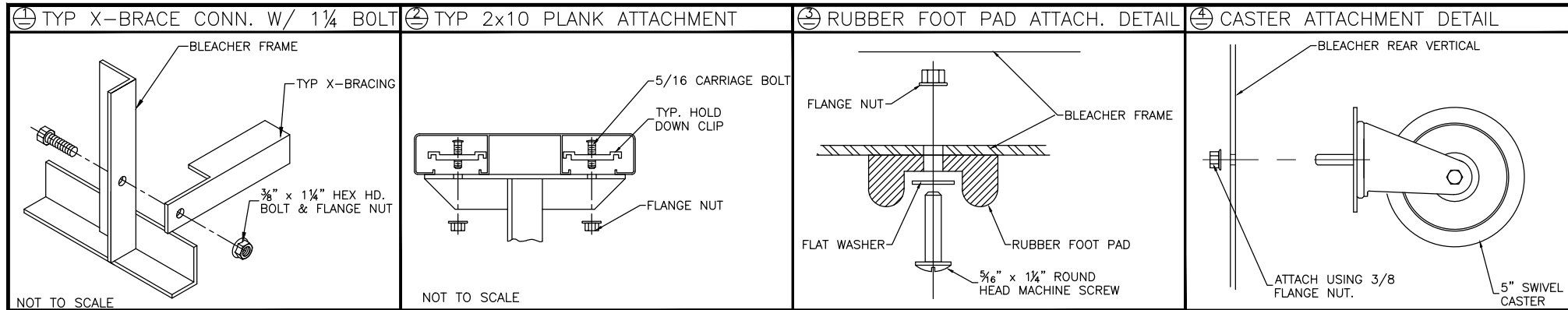

NOTE: MOUNT CASTERS TO END FRAMES ONLY.

WARNING

TIP N' ROLL BLEACHERS ARE SUITABLE FOR INDOOR OR OUTDOOR USE. HOWEVER, THEY SHOULD ONLY BE TIPPED UP ON THE CASTERS INDOORS, DUE TO POTENTIAL WIND HAZARDS IF TIPPED UP OUTDOORS. THESE LIGHT-WEIGHT UNITS ARE EASILY TIPPED UP BY ANY ABLE-BODIED ADULT.

This drawing and all information contained herein is the property of The Park Catalog. and is not to be reproduced without express written permission of this manufacturer. We assume no responsibility for unauthorized use of this drawing. The Park Catalog is not responsible for local permits, local code compliance and occupancy requirements.

SCALE: N.T.S.	APPROVED BY: IMP / /	DRAWN BY:
DATE: / /	TITLE: Bleacher Assembly	
BLEACHER MODEL #:	DRAWING NUMBER: BA.1	

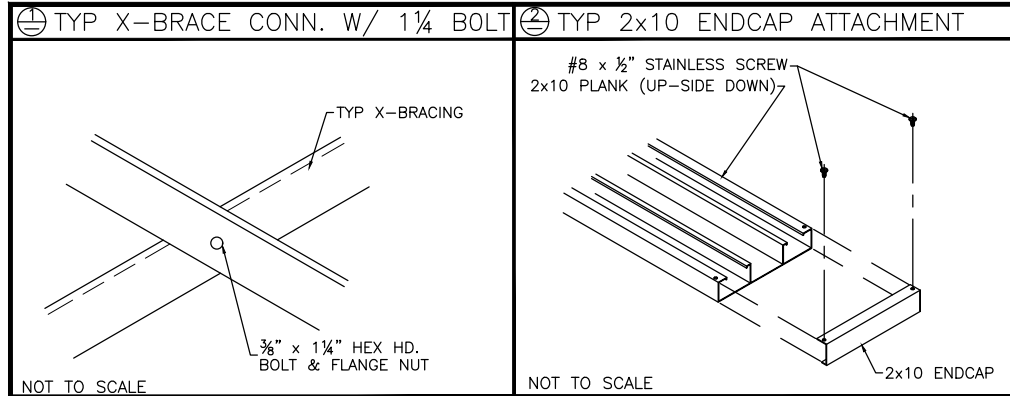

PLANK PLAN

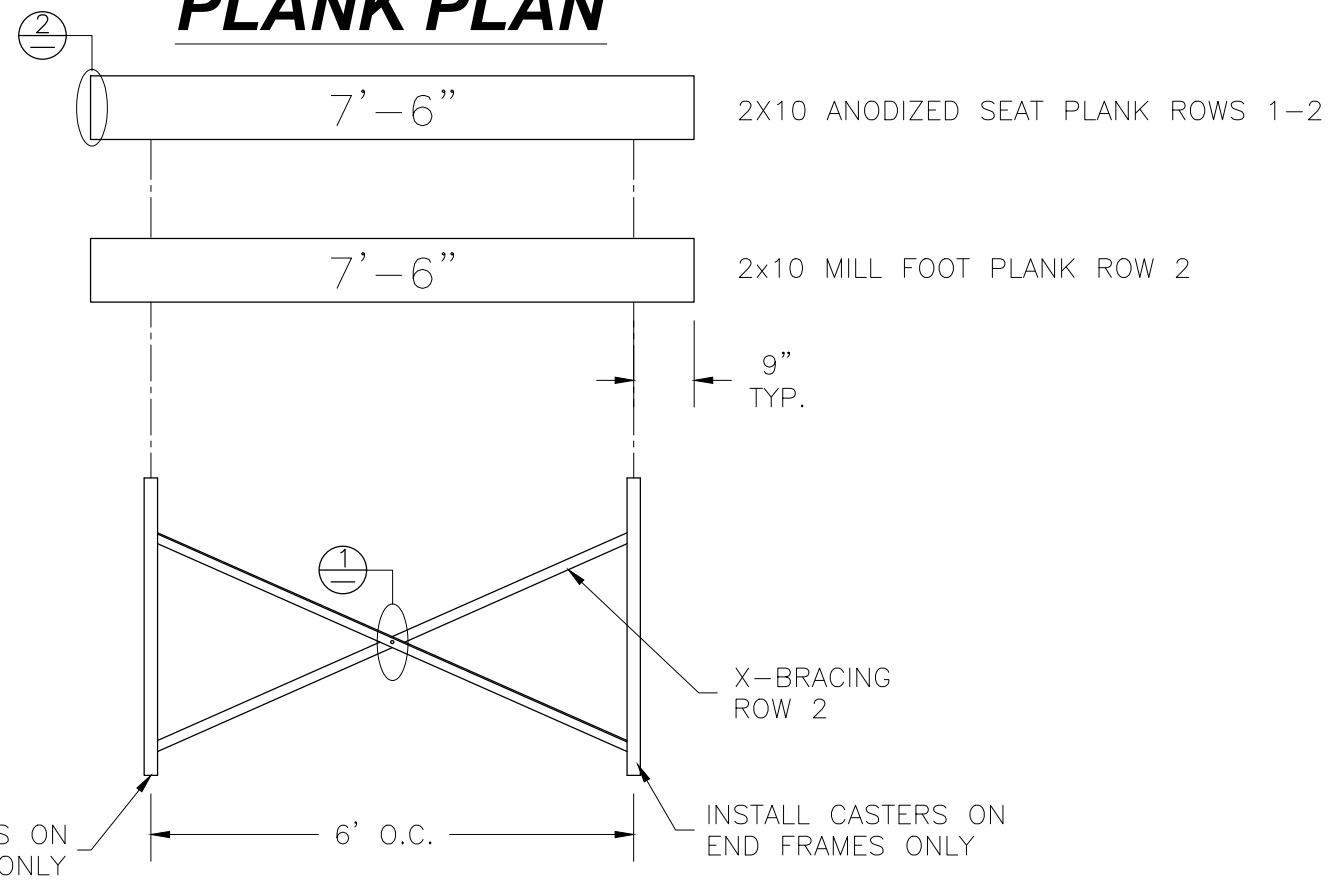

FRAMING PLAN

This drawing and all information contained herein is the property of The Park Catalog, and is not to be reproduced without express written permission of this manufacturer. We assume no responsibility for unauthorized use of this drawing. The Park Catalog is not responsible for local permits, local code compliance and occupancy requirements.

SCALE: N.T.S.	APPROVED BY:	DRAWN BY:
DATE: / /		
TITLE: Plank and Framing Plans		
BLEACHER MODEL #:	DRAWING NUMBER: PF.1	

Click to Print



The Park Catalog
931 Village Blvd Ste 905-354, West
Palm Beach, FL 33409
855-746-5548
noreply@theparkcatalog.com

This item requires a shipping quote.
Please add it to your cart, then click
Request a Quote.

QuickShip  **REQUEST A QUOTE**

Sourcewell 

Awarded Contract

Contract # 081523-NRS

2 Row Tip And Roll Bleachers - Baseline Series

\$1,411.00



Request a quote 

Quick Overview

 **Best Price Guarantee**

 **Bulk Discount**

 **Free Expert Consultation**
800-695-3503

Request a quote 

15' Long



\$1,411.00



2 Row Tip and Roll Bleachers - Baseline Series

Item No: 569-1300
Bleacher Length: 15'

CS.1	- COVER SHEET
TD.1	- BLEACHER SEATING PLAN
BA.1	- BLEACHER ASSEMBLY
PF.1	- PLANK & FRAMING PLAN

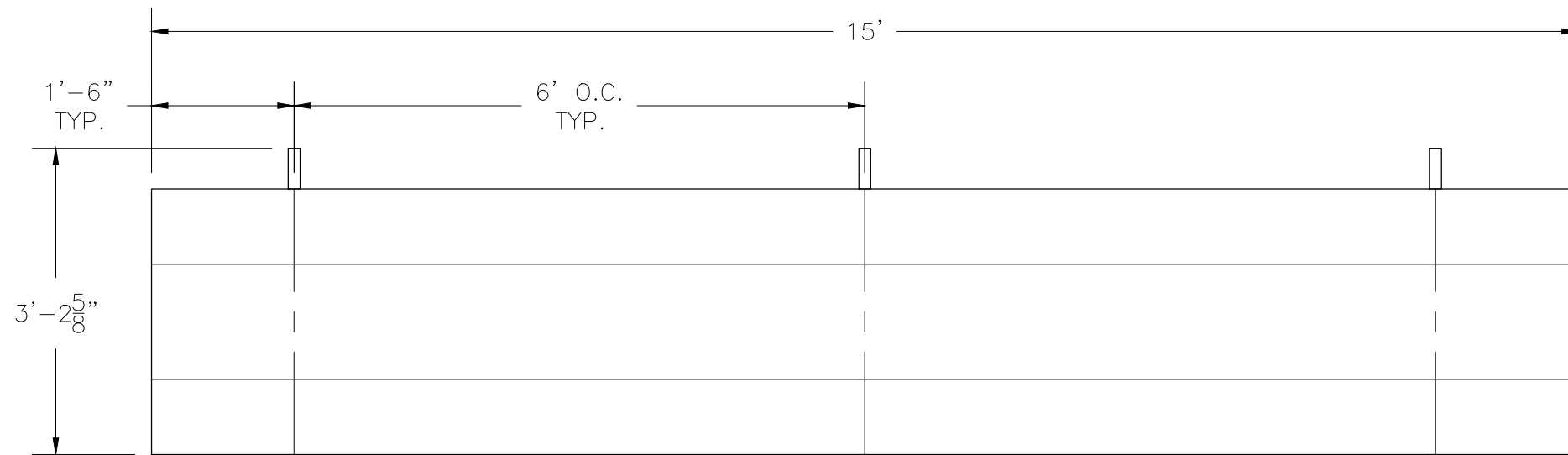

SECTION LENGTH	GROSS SEATS	ACTUAL SEATS	NO. OF ROWS	NET SEATS
15	10.00	10.00	2	20
			NET SEATS	20
			WHEELCHAIR SPACES	0
			TOTAL NET SEATING CAPACITY (BASED ON 18" PER SEAT)	20

This drawing and all information contained herein is the property of The Park Catalog, and is not to be reproduced without express written permission of this manufacturer. We assume no responsibility for unauthorized use of this drawing. The Park Catalog is not responsible for local permits, local code compliance and occupancy requirements.

SCALE: N.T.S.	APPROVED BY: / /	DRAWN BY:
DATE:	TITLE: Bleacher Seating Plan	
BLEACHER MODEL #:	DRAWING NUMBER: TD.1	

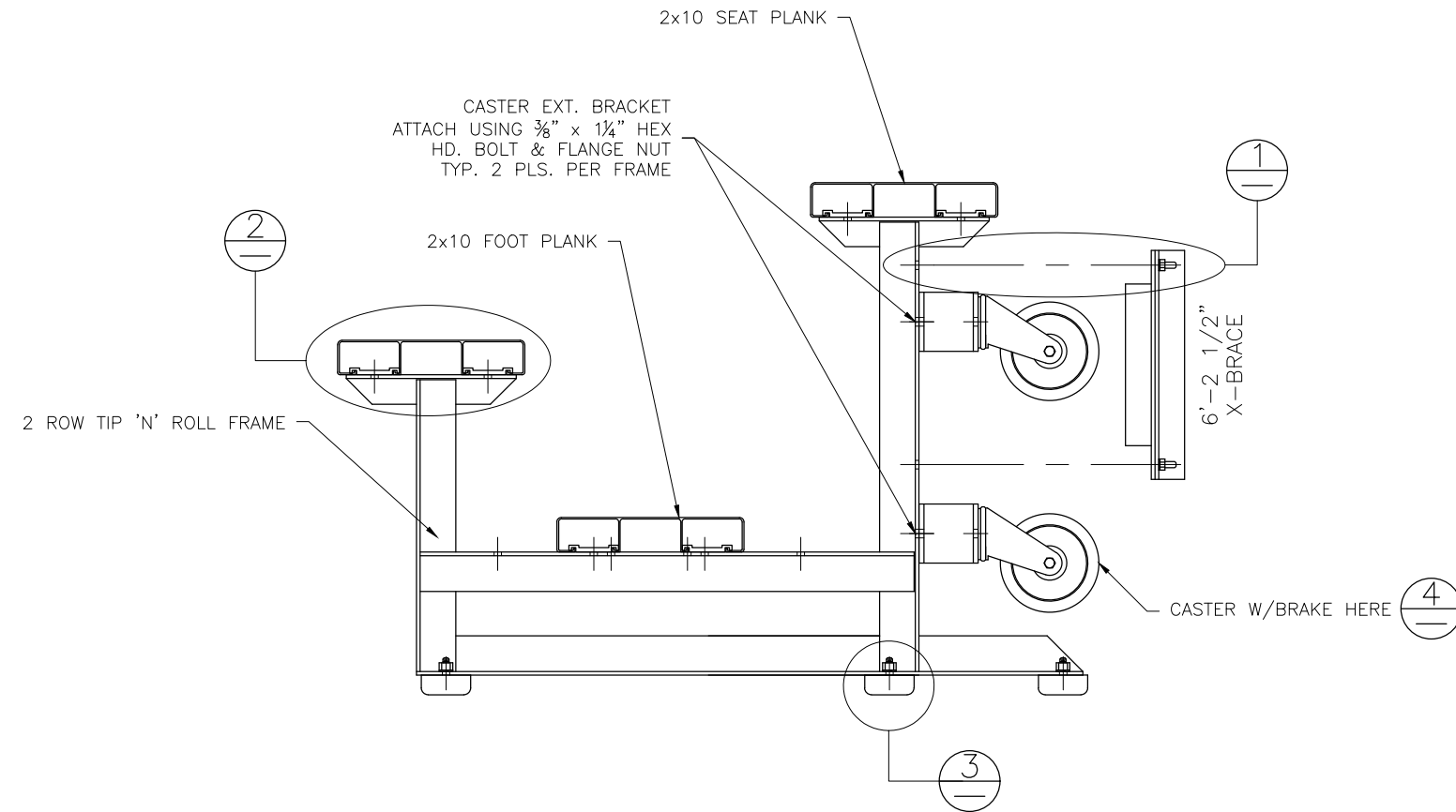
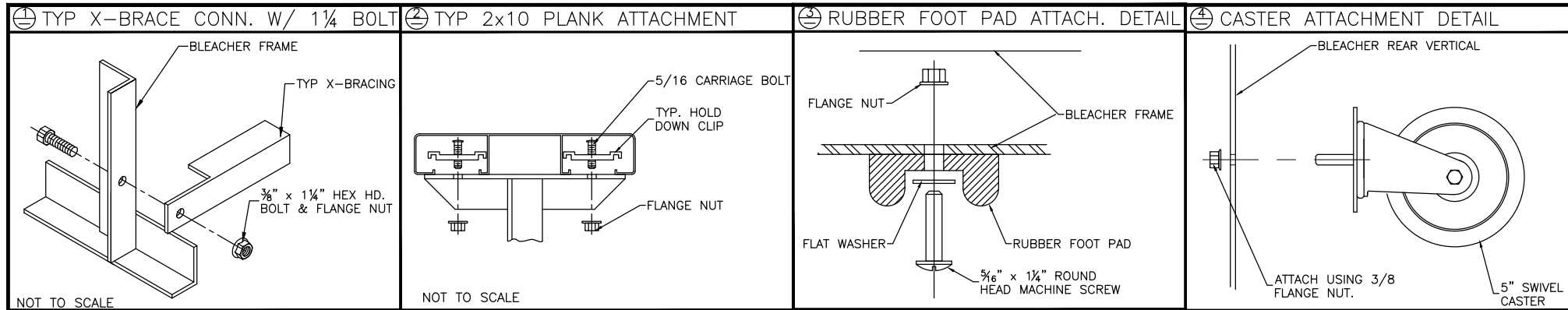

NOTE: MOUNT CASTERS TO END FRAMES ONLY.

WARNING

TIP N' ROLL BLEACHERS ARE SUITABLE FOR INDOOR OR OUTDOOR USE. HOWEVER, THEY SHOULD ONLY BE TIPPED UP ON THE CASTERS INDOORS, DUE TO POTENTIAL WIND HAZARDS IF TIPPED UP OUTDOORS. THESE LIGHT-WEIGHT UNITS ARE EASILY TIPPED UP BY ANY ABLE-BODIED ADULT.

This drawing and all information contained herein is the property of The Park Catalog. and is not to be reproduced without express written permission of this manufacturer. We assume no responsibility for unauthorized use of this drawing. The Park Catalog is not responsible for local permits, local code compliance and occupancy requirements.

SCALE: N.T.S.	APPROVED BY: IMP / /	DRAWN BY:
DATE: / /	TITLE: Bleacher Assembly	
BLEACHER MODEL #:	DRAWING NUMBER: BA.1	

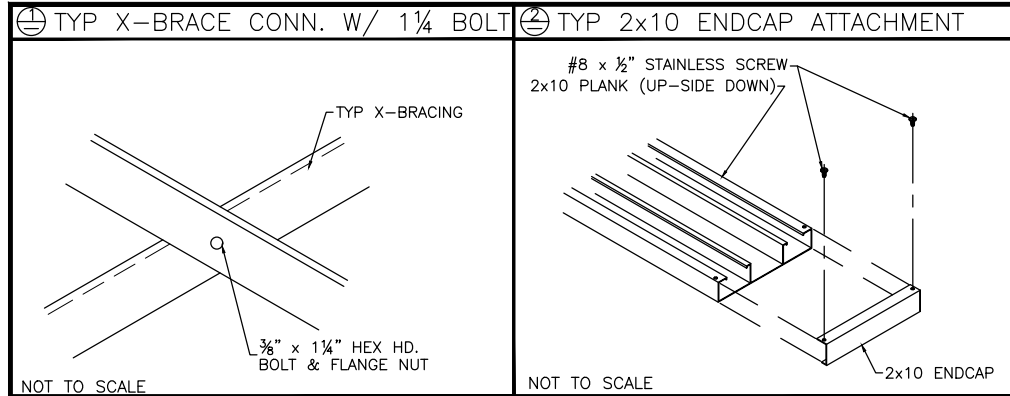

PLANK PLAN

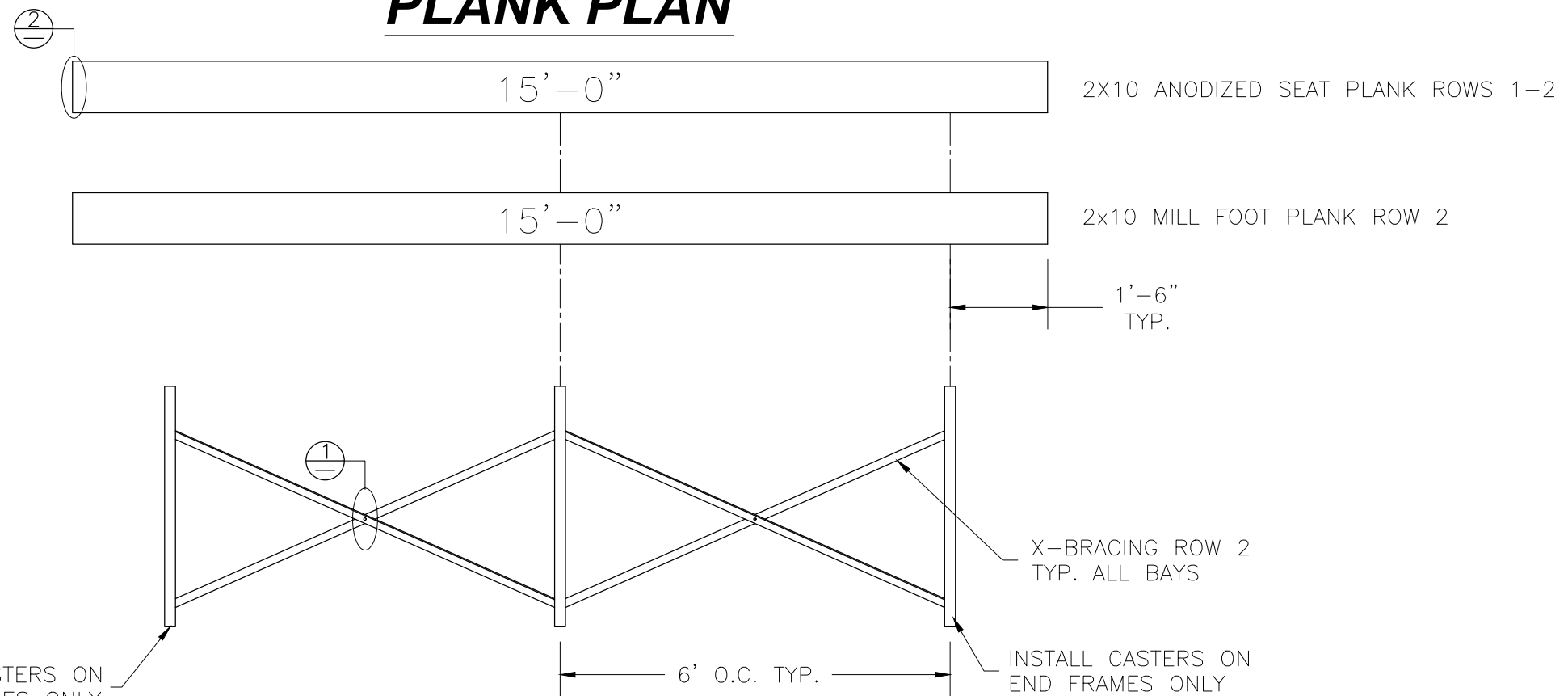

FRAMING PLAN

This drawing and all information contained herein is the property of The Park Catalog. and is not to be reproduced without express written permission of this manufacturer. We assume no responsibility for unauthorized use of this drawing. The Park Catalog is not responsible for local permits, local code compliance and occupancy requirements.

SCALE: N.T.S.	APPROVED BY:	DRAWN BY:
DATE: / /		
TITLE: Plank and Framing Plans		
BLEACHER MODEL #:	DRAWING NUMBER: PF.1	

855-746-5548



thepark

AND FACILITIES
C A T A L O G



Need Help? Chat with a representative now.

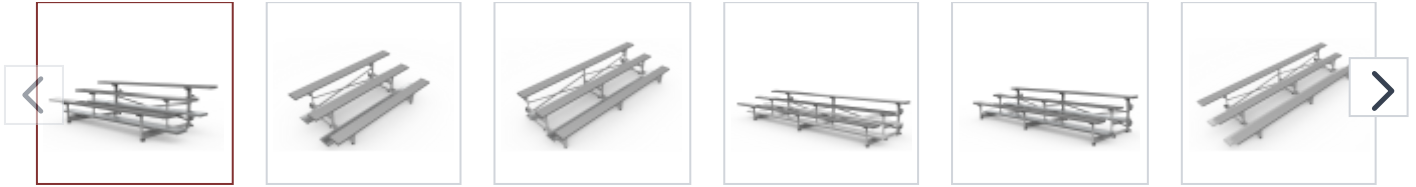

3 Row Tip and Roll Bleachers - Baseline Series

\$1,415.00 / each

Request a quote 

****Quick Ship is available in Quantities of 5 or less****

- 3-rows of seating
- Aluminum frame with swivel casters
- Single foot planks on all rows
- Aluminum angle understructure 8" rise/row
- 2 X 10 anodized aluminum seat plank
- (1) 2 X 10 mill finish aluminum foot plank
- 5" casters with non-marring wheels
- Non-marring rubber foot pads

This item requires a manual freight quote. Please add it to your cart and request a quote, or call 866-280-9894 to get assistance from one of our bleacher experts.



ITEM # #569-1301

 PRINT

PRODUCT RESOURCES

VIEW SPEC SHEET

OPTIONS

Length

7' 6" Long



This item requires a shipping quote.

Please add it to your cart, then click
Request a Quote.

0

ADD TO CART

Request a quote 



**This bleacher system may not meet your local code compliance requirements. It is the customer's responsibility to confirm any necessary code compliance related to bleachers with your local building department and communicate these requirements to The Park Catalog. The Park Catalog will not be held responsible or liable for any bleacher purchase that does not meet local code compliance.*

DESCRIPTION

These bleachers tip and roll away for easy storage and are the ideal solution to your seating needs. This bleacher is easily tipped up onto its swivel casters for movement, and the caster brakes keep the bleacher from rolling when stored. The Tip and Roll Bleachers include non-marring rubber foot pads to protect your floors. The aluminum understructure (frame) reduces weight for easier lifting. If you are looking for a portable bleacher than our Tip and Roll Bleachers are perfect for the job.

Seating Chart

Item #	Bleacher Length	Seats	Weight	QuickShip
569-1301-1	7' 6"	15	160	Yes
569-1301-2	9'	18	173	Yes
569-1301-3	12'	24	219	Yes
569-1301-4	15'	30	246	Yes
569-1301-5	21'	42	343	Yes
569-1301-6	24'	48	392	Yes



[MY ACCOUNT](#)

[CONTACT US](#)

[TERMS & CONDITIONS](#)

[THE PARK BLOG](#)

[ORDER TRACKING](#)

[ABOUT US](#)

[PRODUCT POLICIES](#)

[PRIVACY POLICY](#)

[VIDEO LIBRARY](#)

Talk to an expert:

855-746-5548

Newsletter sign up:

Sign up for our newsletter



Stay connected:



© 2025 The Park Catalog. All Rights Reserved.



Aluminum Bleachers - 7.5', 3 Rows

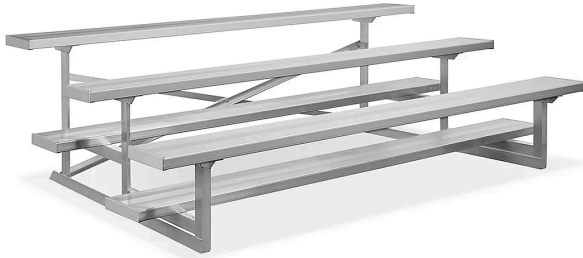

Get the crowd into the game with comfortable seating and elevated views.

- 10" deep aluminum benches and foot rails.
- Welded aluminum frame. No rust.
- [Concrete](#) or [Grass Mounting Hardware](#) and [Wheel Kits](#) sold separately.

[More Images](#)

MODEL NO.	DESCRIPTION	SEATING CAPACITY	SIZE L x W x H	WT. (LBS.)	PRICE EACH		IN STOCK SHIPS TODAY
					1	3+	
H-7229	3 Rows	15	7.5 x 5 x 2'	100	\$1,280	\$1,240	1 <input type="button" value="ADD"/>

SHIPS UNASSEMBLED VIA MOTOR FREIGHT

[+ Additional Info](#) | [+ Parts](#) | [+ Shopping Lists](#) | [Request a Catalog](#)

HUGE SELECTION

LEGENDARY SERVICE

FASTEST DELIVERY



thepark

AND FACILITIES
C A T A L O G

[Home](#) > 3 Row Tip and Roll Bleachers - Baseline Series

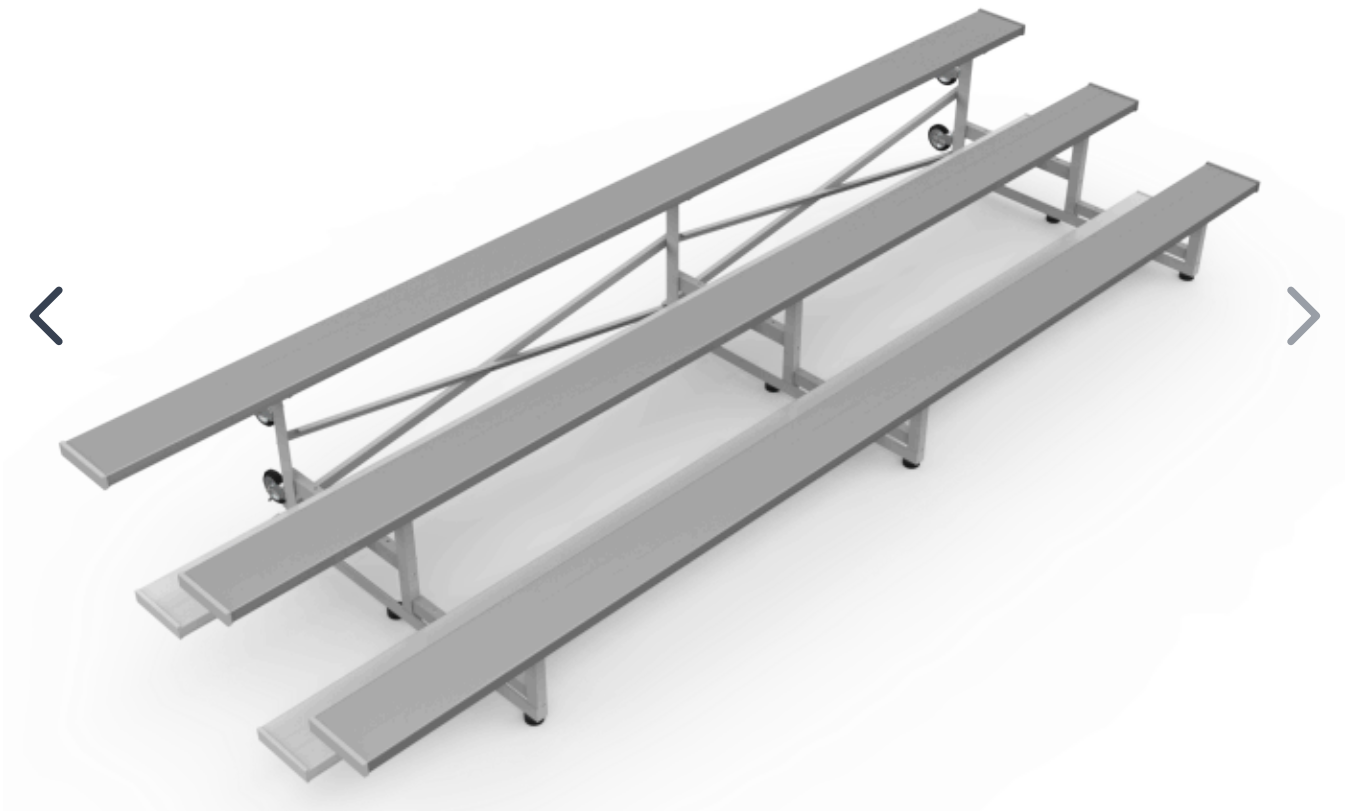

Need Help? Chat with a representative now.

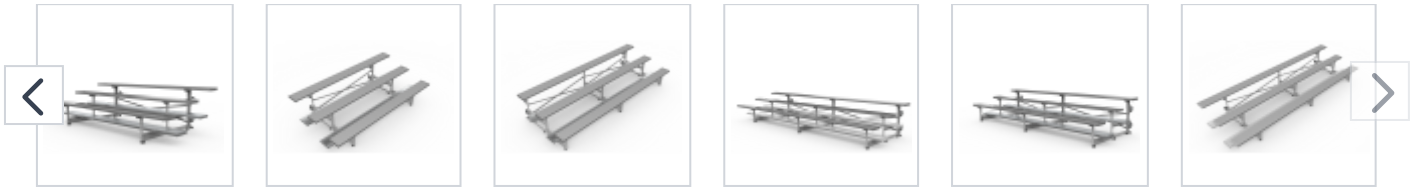

3 Row Tip and Roll Bleachers - Baseline Series

\$1,973.00 / each

Request a quote 

****Quick Ship is available in Quantities of 5 or less****

- 3-rows of seating
- Aluminum frame with swivel casters
- Single foot planks on all rows
- Aluminum angle understructure 8" rise/row
- 2 X 10 anodized aluminum seat plank
- (1) 2 X 10 mill finish aluminum foot plank
- 5" casters with non-marring wheels
- Non-marring rubber foot pads

This item requires a manual freight quote. Please add it to your cart and request a quote, or call 866-280-9894 to get assistance from one of our bleacher experts.



ITEM # #569-1301



PRODUCT RESOURCES

VIEW SPEC SHEET

OPTIONS

Length

15' Long



This item requires a shipping quote.

Please add it to your cart, then click
Request a Quote.

0

ADD TO CART

Request a quote 



**This bleacher system may not meet your local code compliance requirements. It is the customer's responsibility to confirm any necessary code compliance related to bleachers with your local building department and communicate these requirements to The Park Catalog. The Park Catalog will not be held responsible or liable for any bleacher purchase that does not meet local code compliance.*

DESCRIPTION

These bleachers tip and roll away for easy storage and are the ideal solution to your seating needs. This bleacher is easily tipped up onto its swivel casters for movement, and the caster brakes keep the bleacher from rolling when stored. The Tip and Roll Bleachers include non-marring rubber foot pads to protect your floors. The aluminum understructure (frame) reduces weight for easier lifting. If you are looking for a portable bleacher than our Tip and Roll Bleachers are perfect for the job.

Seating Chart

Item #	Bleacher Length	Seats	Weight	QuickShip
569-1301-1	7' 6"	15	160	Yes
569-1301-2	9'	18	173	Yes
569-1301-3	12'	24	219	Yes
569-1301-4	15'	30	246	Yes
569-1301-5	21'	42	343	Yes
569-1301-6	24'	48	392	Yes



[MY ACCOUNT](#)

[CONTACT US](#)

[TERMS & CONDITIONS](#)

[THE PARK BLOG](#)

[ORDER TRACKING](#)

[ABOUT US](#)

[PRODUCT POLICIES](#)

[PRIVACY POLICY](#)

[VIDEO LIBRARY](#)

Talk to an expert:

855-746-5548

Newsletter sign up:

Sign up for our newsletter



Stay connected:



© 2025 The Park Catalog. All Rights Reserved.



GO

Products | Uline Brand | Quick Order | Catalog Request | Special Offers | About Us | Careers

Home > All Products > Facilities Maintenance > Benches > Aluminum Bleachers

Aluminum Bleachers - 15', 3 Rows



Get the crowd into the game with comfortable seating and elevated views.

- 10" deep aluminum benches and foot rails.
- Welded aluminum frame. No rust.
- [Concrete](#) or [Grass Mounting Hardware](#) and [Wheel Kits](#) sold separately.

[More Images](#)

MODEL NO.	DESCRIPTION	SEATING CAPACITY	SIZE L x W x H	WT. (LBS.)	PRICE EACH		IN STOCK SHIPS TODAY
					1	3+	
H-4406	3 Rows	30	15 x 5 x 2'	187	\$2,195	\$2,145	1 ADD

SHIPS UNASSEMBLED VIA MOTOR FREIGHT

[+ Additional Info](#) | [+ Parts](#) | [+ Shopping Lists](#) | [Request a Catalog](#)

HUGE SELECTION

LEGENDARY SERVICE

FASTEST DELIVERY



Tip and Roll Wheel Kit for 3 Row Bleachers



[More Images](#)

Turn stationary bleachers into portable indoor seating.

- Roll, set up and store bleachers with ease.
- 5" non-marring swivel casters, 2 locking.
- Rubber feet protect floor during use.
- Includes hardware.
- Use with [3 Row Bleachers](#).

MODEL NO.	DESCRIPTION	PRICE EACH	IN STOCK
H-4755	Portable Wheel Kit	\$305	1 SHIPS TODAY
			ADD

[Additional Info](#) | [Shopping Lists](#) | [Request a Catalog](#)

HUGE SELECTION

LEGENDARY SERVICE

FASTEST DELIVERY

Bleachers and Bench Colors



SPECIFICATIONS

Sturdy rust-resistant aluminum bench for athletic fields, public parks, and sport complexes that will provide years of use for your team or league.

Constructed of 10" wide anodized aluminum non-skid seat planks and backrests with 2" square heavy-duty rust-resistant steel legs for a strong, stable base.

Player Benches installation choices include portable, in-ground, or surface mount. Available in 7.5', 15', 21' and 27' lengths.

Bleachers include dual braces and rear stabilizing bars for increased strength with galvanized steel understructure. Available in 7.5', 15', 21' and 27' lengths in 2, 3 and 4 row configurations.

Enclosed bleachers add vertical guardrails or chain-link enclosure. Available in 15', 21' and 27' lengths in 5 and 10 row configurations.

Custom Colors

Powder coat options are available on all benches and bleachers. Coordinate the Bleacher/Benches with your project colors.



Risers and double foot planks added to bleachers over 30" high for code and safety regulations. Specify plank, understructure, and/or guardrail colors when ordering powder coat option. Powder coat finish not available on chain-link enclosures or 10 row bleachers.



COLORCHART

Actual colors may vary slightly from samples

Textured - Non-Skid

			
BLACK	NAVY BLUE RAL 5003 PMS 540C	ROYAL BLUE RAL 5005 PMS 294C	MAROON RAL 3005 PMS 490C
			
RED RAL 3020 PMS 485C	YELLOW RAL 1018 PMS 123C	DARK GREEN RAL 6005 PMS 3308C	KELLY GREEN RAL 6024 PMS 348
			
*GOLD PM212458 PMS 1245C	PRO YELLOW RAL 1016 PMS 604C	WHITE	

Not Textured

		
ORANGE RAL 2004 PMS 1655	PURPLE PPF60058 PMS 669C	GREY RAL 7045 PMS 423C

Item #

**Monterra Community Development District
Board of Supervisors Agenda Memorandum
Office of the District Manager**

Meeting Date: July 1, 2026
Subject: Consideration of proposal to clean storm drainage system

We have two quotes to clean the storm drainage system for the district. This is something that needs to be completed annually



Lynne Ladner



Brett Konchak
 Commercial Manager
 9001 NW 97th Terrace Suite F,
 Medley, FL 33178
 3014 N US Hwy. Suite 700
 Tampa, FL 33619
 Tel: 561-993-6464
 E-Mail: BKonchak@azuria.com

SALESFORCE ID SO-00222816

**ATTN: Lynne Ladner, District Manager
 Monterra Community Development District
 Inframark**

**CELL: 561-446-4821
 EMAIL: lladner@inframark.com**

**RE: Monterra CDD, Drainage System Cleaning
 Proposal # 2026123**

Insituform Technologies, LLC (“ITL”) is pleased to provide this Proposal (“Proposal”) for the scope of work detailed below for the above-referenced Project (“Project”).

PRICING

The following pricing shall apply to work performed by ITL. All pricing is valid for 30 days, unless otherwise extended by ITLLC.

Item	Description	Units	Quantity	Unit Cost	Total Cost
	Cleaning of storm drain catch basins, along with hydro jetting of all connecting pipes	EA	29	\$175.00	\$5,075.00
	Debris Disposal	LS	1	\$250.00	\$250.00
				TOTAL =	\$5,325.00

The following items are excluded from ITL's above Pricing and Scope of Services / Responsibilities stated in this Agreement. These items, if necessary, applicable or otherwise required, shall be furnished by the Customer, in the Customer's direction and at no cost to ITL or may, upon mutual agreement in writing between ITL and Customer, be provided by ITL at an additional cost:

1. Permits, licenses and construction easements.
2. Customer shall be responsible for locating all manholes on the project and ensuring access is possible.
3. Payment and Performance bonds. If payment and performance bonds are required, add 2.5% to the total Project cost.
4. Removal and disposal of any hazardous or toxic materials encountered during the Project.
5. Holiday work, rush delivery or adverse weather work (as defined by ITL).
6. Certified Professional Engineer stamped designs. Will be provided, at additional cost, if required in specifications.
7. Additional premiums for special insurance coverage(s) specific to any project if required.

ITL GENERAL SCOPE OF WORK / RESPONSIBILITIES

ITL will provide the following:

1. Standard insurance coverage with the following limits:
 - o General Liability: \$2,000,000 per occurrence/\$4,000,000 aggregate
 - o Auto: \$2,000,000 Combined Single Limit
 - o Workers Compensation: Statutory with \$1,000,000 Employer's Liability

The above insurance shall not include Primary and Non-Contributory Coverage and ITL shall not provide a Waiver of Subrogation endorsement.

NOTE: Modifications to the Scope of Work/Responsibilities of ITL may result in a change in price and/or duration.

TERMS AND CONDITIONS

By executing this Proposal, Customer shall be subject to all of the terms and conditions including those contained at the following link: [Insituform Terms and Conditions](#) (the "Insituform Terms and Conditions"). The terms of this Agreement (including the Insituform Terms and Conditions) shall be controlling over others. The terms and conditions of this Proposal form the entire agreement "Agreement" between the parties. All other terms, proposals, negotiations, representations, recommendations, statements or agreements, whether made or issued contemporaneously or previously, are excluded from and are not a part of this Proposal and have no binding or enforceable effect. This Proposal, if accepted, shall be binding on the parties and their respective successors and assigns.

ACCEPTANCE

Please do not hesitate to contact me with any further questions at

Very truly yours,

Insituform Technologies, LLC.

Brett Konchak
Commercial Manager



Accepted By: _____
(signed)

Date: _____

(print name)

Title: _____

Elizabeth,

Below is the storm drain cleaning pricing for the Monterra communities:

- Corta Bella Community: \$3,950.00
- Vista del Prado Community: \$1,492.50
- Bella Terra Community: \$2,572.50
- Cascada Community: \$2,707.50
- Capistrano and Clubhouse: \$3,247.50
- Cascada Isle Community: \$2,842.50
- Solano Community: \$3,247.50
- La Costa Community: \$3,815.00
- Estada Community: \$6,245.00
- Vista del Sol Community: \$8,837.50
- Solano Avenue: \$5,435.00
- Taramea Avenue: \$3,112.50
- Monterra Boulevard: \$4,490.00

These are the **same rates previously approved and performed in 2024**, which we've kept consistent as a courtesy.

The last service was completed in **December**, so ideally we would keep the same timing this year, though we can also accommodate an earlier schedule if needed.

These rates are being **held temporarily**, so once approved, we can move forward with scheduling and invoicing accordingly.

Please let me know how you'd like to proceed.

Thank you

Giovanny Brenes
Account Management
Dolphin Park of Commerce
2061 NW 112th Ave, Unit 131
Miami, FL 33172
Office: (305) 859-1314
Mobile: (305) 793-7120
Fax: (305) 537-6420

www.xpumpingsolutions.com

**Monterra
Community Development District**

11555 Heron Bay Boulevard, Suite 201, Coral Springs, Florida 33076

Phone (954) 603-0033 Website: <https://www.monterracdd.com>

June 18, 2026

[This is Not a Bill - Do Not Pay]

By US Mail, First Class Delivery

[insert property owner name/address]

Parcel ID: _____

*Re: Monterra Community Development District
Notice of Public Hearing on Operation and Maintenance Assessments*

Dear Property Owner:

The Monterra Community Development District (the “**District**”) will hold a public hearing on **Wednesday, August 5, 2026, at 6:00 p.m. at the Club Monterra, 8451 Monterra Boulevard, Cooper City, Florida 33024** for the purposes of (i) adopting the District’s proposed budget for the fiscal year beginning October 1, 2026, and ending September 30, 2027 (the “Proposed Budget”), and (ii) levying operations and maintenance assessments (**O&M Assessments**) to fund the Proposed Budget. You are receiving this notice because Broward County records indicate that you are a property owner within the District.

This letter is notice of a proposed increase in your Non-Ad Valorem assessment for the Proposed Budget. A “Non-Ad Valorem” assessment is a charge based on the benefit your property receives from the District, not on your property’s market value. For the upcoming fiscal year, the District proposes to increase the O&M Assessments by approximately ____% per year, applied across all assessable property within the District.¹

The District is a local unit of special-purpose government established pursuant to Chapter 190, Florida Statutes. The District owns and maintains certain infrastructure improvements within the District. Although the Proposed Budget has not been finalized, the District’s reasoning behind the proposed increase is to cover increased costs for operations and maintenance and to ensure the District is able to maintain its infrastructure. The O&M Assessments pay for the items described in the Proposed Budget, including, but not limited to, administrative costs,

¹If approved, this percentage will serve as the “maximum rate” for future O&M Assessments, and no mailed notice will be provided unless there is a proposed increase or another criterion within Section 197.3632(4), Florida Statutes is triggered.

maintenance and upkeep throughout the community, and capital projects. The District expects to annually collect no more than \$4,871,623.00, inclusive of collection costs and early payment discounts, in gross revenue as a result of the O&M Assessments.

The O&M Assessments are allocated based on benefit from the operations and services of the District pursuant to an equivalent assessment unit (“EAU”) basis. EAUs are units of measurement assigned to each lot according to its product type as described in the Proposed Budget. The assessment amount for each lot is calculated by dividing the proposed budget by the total EAUs and then multiplying that number by the EAU factor for the product type. In general, this means that larger lots and higher-benefit product types pay proportionally more, while smaller or lower-benefit lots pay less. (“Product type” refers to the category of home or lot assigned to your parcel, as defined in the Proposed Budget.)

The O&M Assessments (as well as any debt assessments or other District assessments) are collected by the Broward County Tax Collector on the Broward County tax bill.² By operation of law, the District’s assessments each year constitute a lien against your property located within the District just as do each year’s property taxes. **It is important to pay your assessment since failure to pay will cause a tax certificate to be issued against the property which may result in loss of title.** This letter is not a bill, and no payment is due in response to it. Your O&M Assessment will be included on your annual Broward County property tax bill, which you should continue to pay in the usual manner.

Please note that you have the right to appear at this public hearing and express any objections, suggestions, or comments you may have. You may also file written objections within 20 days of the date of this letter addressed to the District Manager at the address provided herein. You may submit written objections in advance, appear at the public hearing, or do both. The public hearing may be continued to a date, time, and place certain that will be announced at the hearing. Each person who decides to appeal any decision made by the District’s Board of Supervisors with respect to any matter considered at the public hearing or meeting is advised that person will need a record of proceedings and that accordingly, the person may need to ensure that a verbatim record of the proceedings is made, including the testimony and evidence upon which such appeal is to be based.

The Monterra Board of Supervisors (the “Board”) plans to continue investing in the District through the completion of certain capital projects. The District has included funding for these capital projects in the Proposed Budget. The Board is aware that maintaining the District and completion of capital projects is challenging in the current economic climate. The Board has determined that using a portion of cash reserves is prudent so that these capital projects can be

²The O&M Assessments are in addition to the District’s debt assessments or other assessments (if any). The tax bill combines the District’s assessments. There are no changes to the District’s other assessments from the previous year.

completed for the benefit of the District, while acknowledging the financial impact on property owners in the District.

A copy of the proposed budget and the agenda may be viewed on the District's website at least two days before the meeting. I hope this information is helpful. If you have any questions, please do not hesitate to contact my office at the address listed in the header above, via email at lladner@inframark.com or via phone at 561-446-4821.

Sincerely,

Lynne Ladner
District Manager